

THYSSEN MINING

# Report



English Edition

[www.thyssen-schachtbau.com](http://www.thyssen-schachtbau.com)

2017/18







## IMPRINT

### *Publisher:*

THYSSEN SCHACHTBAU GMBH  
Sandstraße 107-135  
45473 Mülheim an der Ruhr  
Phone +49 208 3002 - 0  
Fax +49 208 3002 - 219  
info@ts-gruppe.com  
www.thyssen-schachtbau.com

### *Editing:*

Jeanette Meier  
Joachim Ravenstein  
Markus Westermeyer

### *Translation (english):*

KeyCom Konferenzdolmetschen  
Christa Gzil

### *Translation (russian):*

Lisa Zaydman

### *Layout:*

Iris Huber, denkbetrieb.de, Werl

### *Photos:*

Employees TS Group  
Archive TS  
Archives TS-Subsidiaries  
Employees from project partners

### *Printing:*

Druckhaus Cramer, Greven  
www.cramer.de

### *Cover picture:*

Ursula Ahlers  
Mining activities of  
THYSSEN SCHACHTBAU

### *Cover picture inside:*

THYSSEN SCHACHTBAU – company  
building with special division shaft  
sinking and drilling

All rights reserved

© THYSSEN SCHACHTBAU GMBH

Copy and storage on digital media  
not without prior permission of the  
publisher



## THYSSEN MINING Report 2017/18

# C O N T E N T

	2	A Word from the Management Board
	6	THYSSEN MINING – Local Challenges – Global Solutions
	7	The Thyssen Mining Group: Global partners
	14	THYSSEN SCHACHTBAU GMBH – occupational health and safety
<b>ROADWAY DRIVAGE</b>	18	Ibbenbüren colliery – anthracite coal with international reputation
	21	Driving deep-level face headings at Prosper-Haniel colliery
	27	The Donskoi GOK project: status report on roadway drirage operations
<b>MINING</b>	30	TMCC – Mining for Barrels
	33	Byrne-cut Offshore Tanzania Ltd. increases advance rate at Bulyanhulu Gold Mine
	35	Implementation of automated drilling for high speed development
<b>SHAFT SINKING</b>	37	Twice a 2,000 meter shaft for Norilsk Nickel
	44	‘By reefer container through the eternal ice.’
	46	Sinking two freeze shafts for Uralkali
	49	Austria welcomes a new major project at the Semmering Base Tunnel
	53	Safe and efficient: Shaft sinking at the Brenner Base Tunnel
	56	Delivering a professional service at the esco-owned Borth salt mine
	60	30 years of THYSSEN SCHACHTBAU operations at the DBE exploratory mine Gorleben
	66	Repository Morsleben – Building a bitumen and ballast abutment seal
	69	Radioactive waste repository Konrad – Status of work
	72	Mikwan Well 4-24 recovery project
	76	McArthur River – Maximizing the life expectancy of an uranium mine
	80	Stopping leaks in Manhattan
<b>DRILLING</b>	82	Megaproject ‘Freeze plant for Gremyachinski mine’
	85	Joint Venture for the exploration of potash and phosphate deposits in the RF
	86	Starting again – shaft number 3 beckons!
	89	TIWAG commissions exploration and drainage work in the Klargarten exploratory drift
	91	Underground exploration drilling for the shaft Asse 5
	94	Safety is paramount in targeted exploration of mineral deposits
	96	Building the world’s steepest funicular
	98	Raise boring – a ventilation shaft in Macedonia
	99	Raise boring in Austria: GKI – ‘the fastest raise in the world!’
<b>PLANNING &amp; INNOVATION</b>	100	The changing face of the Engineering Office related to the globalisation
	102	Taking the next step towards implementation
	104	Mining Plus in Australia marks 10 years of success
	107	LIDAR scanning Newmont Leeville No. 3 ventilation shaft
<b>CONSTRUCTION</b>	109	Long-Term solution to mine-water drainage in Breitenbrunn
	112	Exploration work in shaft Halle for Teutschenthal mine
<b>PRODUCTION &amp; SERVICE</b>	114	CMAC-THYSSEN Mining Group: A culture change for the future
	117	Thyssen Mining Construction of Canada Ltd. launches Living Sky Industrial Inc.
	119	Jetcrete North America: Filling Gaps in the Shotcrete Industry
	121	Murray Engineering Installs State of the Art Pump Station at Indonesian Mine
	124	T+S – New milling equipment for the in-house machine pool
	126	T+S – Positive developments in crane and gate technology
	128	A new single-rope winder for Unterbreizbach number 1 shaft
	130	The new lift and clamping system by OLKO-Maschinentechnik GmbH
	132	Replacement of hot-gas generators in coal drying and grinding plant
	134	Pontoon dredger goes Las Vegas
<b>HISTORY</b>	136	Insights into shaft construction practice in the early 20th century
<b>INTERIOUR FITTINGS</b>	140	DIG DEUTSCHE INNENBAU GMBH – Your partner for high-end interiors
<b>ADMINISTRATION</b>	142	The work of the Purchasing and Logistics Department
<b>TRAINING</b>	143	Mining technologists – vocational training in the mining industry



Dipl.-Kfm. Michael Klein  
Chief Executive Officer  
THYSSEN SCHACHTBAU HOLDING

*Ladies and gentlemen,  
business colleagues and associates,  
fellow workers,*

The 2017/18 THYSSEN MINING Report again features its customary review of the wide-ranging international activities of the THYSSEN SCHACHTBAU Corporation and of the Thyssen Mining Construction of Canada Group and the Byrncut Group. The Report also describes the broad range of services available, the current technology developments and the challenges that face us at this present time.

The Thyssen Mining Group employs a total workforce of some 6,500 persons and its overall business operations reported a total turnover for the year of nearly 1.5 bn euros.

We shall continue to employ our technical know-how to assist our national and international clients and partners in developing and accessing mineral deposits and natural resources of every kind. The global demand for these commodities continues to remain at a high level.

The following summary reports present the activities of the various companies that make up the THYSSEN SCHACHTBAU Corporation:

#### ■ THYSSEN SCHACHTBAU HOLDING GMBH

THYSSEN SCHACHTBAU HOLDING functions as a central services department in managing and coordinating the commercial activities of the THYSSEN SCHACHTBAU Corporation at home and overseas.

The Group is organised into four business areas: mining, construction, production and facility management.

THYSSEN SCHACHTBAU HOLDING is directly or indirectly involved with the following affiliated companies: THYSSEN SCHACHTBAU GMBH, the specialist mining company Ruhr-Lippe mbH, 000 Thyssen Mining Construction East, TOO SCHACHTBAU Kazakhstan, TS BAU GMBH, DIG DEUTSCHE INNENBAU GMBH, TS Technologie + Service GmbH, the pipeline and plant engineering company RAR Rohr- und Anlagenbau Recklinghausen GmbH, OLKO-Maschinenteknik GmbH, EMSCHER AUFBEREITUNG GMBH and Thyssen Schachtbau Immobilien GmbH.

#### ■ THYSSEN SCHACHTBAU GMBH – Shaft Sinking and Drilling Division

The Shaft Sinking and Drilling Division is a key part of our globally established, internationally active enterprise.

The focus of this operation, which has a company history going back nearly 150 years, is on developing and accessing natural deposits. As well as using conventional shaft sinking methods, which involve the latest drilling and blasting



techniques, the Division also specialises in cementation and shaft freezing operations and can in addition deploy fully mechanised boring machines capable of creating shaft diameters of over 8 m.

The most important major projects currently under way in Western Europe are at the Konrad waste repository and the Semmering Base Tunnel in Austria.

The Division has also recently gained a foothold in the Russian raw materials market and so far some 70 contracts have been acquired from leading clients in this field.

A large number of workshops and branch offices have now been set up around the world to help plan out and execute these challenging tasks.

### ■ THYSSEN SCHACHTBAU GMBH – Drivage and Mine Water Drainage Division

The Drivage and Mine Water Drainage Division mainly carries out work on behalf of RAG Deutsche Steinkohle AG at its remaining German collieries.

These operations primarily consist of roadheading assignments and the excavation of underground cavities, along with a wide range of other mining-related services.

One of the largest underground projects being carried out at the present time involves the construction of a 2,200 m-long mine-water drainage tunnel that will connect the former Prosper-Haniel colliery to the old Möller-Rheinbaben mine.

Given that Germany's active coal mining industry is to be closed down at the end of 2018 in line with government policy making, the focus of operations in this sector is now shifting towards the consolidation, preservation and stabilisation of former mine workings, the filling of underground cavities and disused mine shafts and the conversion of existing mine sites into water wells as part of the long-term water-management programme.

The Division is currently working on a contract for RAG to convert a complete former Saarland mine into a water collection well.

The Division receives significant support from our affiliated mining specialists Ruhr-Lippe in the execution of its activities.

### ■ 000 Thyssen Mining Construction East

This company was originally responsible for the import and export of machinery and equipment. It currently undertakes a whole range of mining-related projects in Russia on a stand-alone basis.

The company's commercial activities are expected to see continuous expansion in the years ahead.

### ■ T00 SCHACHTBAU Kazakhstan

T00 SCHACHTBAU Kazakhstan is a joint enterprise with SCHACHTBAU NORDHAUSEN GmbH (each partner has a 50% share of ownership). The aim of the company is to acquire contracts and projects in the Kazakh market.

The first major project involved the excavation of a 4,150 m-long mine roadway at Chromtau, which has now been extended to a distance of over 6,000 m.

### ■ TS BAU GMBH

TS BAU, which is based at Jena (Thuringia) and Riesa (Saxony), employs a staff of some 340 and is active in all the major economic centres throughout Germany.

In addition to structural engineering and industrial and commercial construction, including turnkey contracts, the company is mainly engaged in landfill projects, highway engineering, track-laying and civil engineering, demolition work with waste recycling, specialist mining projects, pipeline construction, trenchless pipe-laying and the renovation of water mains and sewer systems using special operating technology.

The company portfolio also includes two participating interests in a landfill site and in an extractive enterprise.

Major clients include various network operators, Deutsche Bahn and the automotive industry.

### ■ DIG DEUTSCHE INNENBAU GMBH

DIG DEUTSCHE INNENBAU has for many years been the number one choice when it comes to high-end interior finishing and installations. The company's sphere of operations includes the planning and execution of modern interior design projects in the widest sense. DIG is one of Germany's leading general contractors for complete property fit-outs. Starting with the initial consultation right through to the finished job the company's key specialisation is standardised





drywall construction and sophisticated fit-outs for major building projects. This includes airports, hospitals, museums, theatres, banks, office buildings and representative shopping centres. Well over 500 projects have already been successfully delivered representing a total financial volume of some 1.5 bn euros.

The largest projects currently under way are: the 5-star Hotel Fontenay, Hamburg, the Living Circle project (conversion of the former Thyssen Trade Centre into 340 residential units), Dusseldorf, and the Elbe Philharmonic Hall (42 luxury apartments), Hamburg.

### ■ TS Technologie + Service GmbH

TS Technologie + Service is a dynamic, forward-looking services company. By employing the latest high-tech plant and equipment the aim is to deliver individual solutions made to order from conception through to technical execution.

The wide range of services available includes welding engineering, machining, repair and assembly work, building technology, crane and door systems, electrical engineering, general engineering, maintenance and dismantling. These services can be provided either individually or as complete package solutions. The company portfolio has recently been extended to cover the supply and installation of garage and house doors, which includes the private client market.

The company's assembly services are used by major clients such as Hüttenwerke Krupp Mannesmann GmbH and thyssenkrupp Steel Europe AG.

With a pool of high-performance machinery, backed up by 7,600 m<sup>2</sup> of production space with crane capacity for individual loads weighing up to 100 t, the company is well prepared for the fabrication of large-sized and heavyweight items in-house.

### ■ RAR Rohr- und Anlagenbau Recklinghausen GmbH

RAR Rohr- und Anlagenbau Recklinghausen has been part of the TS Group since 2016. The company can draw on extensive know-how backed up by years of experience and a strong tradition for high-quality service to customers requiring pipeline prefabrication and assembly work based on a wide variety of pipe diameters and pressure ratings.

The company's portfolio comprises general pipeline construction, buried pipelining, industrial engineering, inspection and maintenance work and a full range of planning services.

A number of framework agreements have also been set up at various locations with high-profile clients such as Evonik, Rütgers und Pilkington.

Close ties with sister company TS Technologie + Service GmbH have created a strategic partnership that extends the Group's range of products and services and enables us to be optimistic about the future.

### ■ OLKO-Maschinentechnik GmbH

OLKO-Maschinentechnik undertakes heavy engineering projects for both national and international clients engaged in the mining and specialised mechanical engineering sectors.

The company is a market leader in the construction of winding machines and shaft sinking gear and also supplies building materials technology.

The development of products in-house has helped the company access international markets such as Russia, Turkmenistan and China.

Having OLKO on board puts the Group in a position 'to supply the entire mining sector (including all associated winding and hoisting equipment) from a single source'.

### ■ EMSCHER AUFBEREITUNG GMBH

EMSCHER AUFBEREITUNG has been producing coal for the PCI market (pulverised coal injection) for nearly 60 years. PCI coal has become an increasingly important factor in the pig-



iron production industry as a result of global developments in raw-material prices, especially for coke, oil and gas.

The company operates six drying and grinding units at its Duisburg production plant and consequently has hands-on expertise in managing all the process stages involved, including an understanding of the different grades of international coal and petroleum coke that are fed into the drier-grinders.

EMSCHER AUFBEREITUNG has since 1987 been the sole supplier of PCI coal to all the blast furnaces operated by thyssenkrupp Steel Europe AG in Germany. The client has specified absolute security of supply round the clock for 365 days and year.

### ■ Thyssen Schachtbau Immobilien GmbH

Thyssen Schachtbau Immobilien manages the property portfolio of the THYSSEN SCHACHTBAU Corporation with a view to meeting both in-house and third-party requirements. This portfolio mainly comprises office buildings and workshop space, but also includes real estate and former industrial land.

TSI has for many years been investing in modernisation and renovation schemes themed on climate and environment protection. One example of this initiative is the rooftop photovoltaics system that has been installed at Sandstrasse in Mulheim. This has an output of 320 kWp and is one of the largest installations of its kind in the entire region.

Two further enterprises in Canada and Australia go to make up the Thyssen Mining Group:

### ■ Thyssen Mining Construction of Canada Group

Thyssen Mining Construction of Canada Ltd., which has its head office at Regina in Saskatchewan, is one of Canada's leading specialist mining contractors.

The business group includes a number of subsidiary companies, namely CMAC-Thyssen Mining Group Inc. and the Joint Ventures Associated Mining Construction Inc., Jetcrete North America, Mudjatik Thyssen Mining and Sovereign-Thyssen.

Two further companies, Living Sky Industrial Inc. and Northwest Fabricators Ltd., undertake assembly and erection projects for the structural steel and pipework engineering sectors.

### ■ Byrnegut Group

Through its many affiliated companies the Byrnegut Group has for more than 30 years been operating successfully as a provider of services and bespoke solutions for the mining industry and other sectors beyond.

The Group comprises Byrnegut Australia Pty. Ltd. and Byrnegut Offshore Pty. Ltd., both with head offices in Perth.

Byrnegut Australia Pty. Ltd. is Australia's leading specialist mining contractor. The company undertakes mining projects of all kinds throughout the island continent on behalf of clients engaged in the extraction of gold, nickel, copper, lead and zinc.

Byrnegut Offshore Pty. Ltd. offers its expertise and know-how to international clients around the world.

*Dear Readers,*  
as the company synopses show, we are now in a position to offer our homeland and international customers a comprehensive portfolio of products and services.

We bring to the table top-quality technology, innovative ideas and highly professional skills and we can guarantee performance of the highest standards when it comes to quality, safety and adherence to deadlines.

Our corporate philosophy means behaving responsibly at all times for the benefit of our customers, suppliers and service providers and maintaining a strict adherence to safety regulations on health and safety matters and environmental protection, which benefits the wellbeing of our employees and the community at large.

We trust you will enjoy reading about some of the exciting projects involving our various Group companies and we hope that this edition of our Mining Report provides an informative insight into the varied and interesting activities of the Thyssen Mining Group.

With my best regards



Michael Klein





# THYSSEN MINING – Local Challenges – Global Solutions

**The history of Thyssen Mining in North America goes back to 1960, when a small team of ground freezing and shaft sinking experts from Germany travelled to Saskatchewan, Canada, to assist with the sinking of shafts for the emerging potash industry. In 1964, Thyssen Mining Construction of Canada Ltd. (TMCC) was established. By 1972, with most of the potash shafts completed, the Thyssen Group made the decision to maintain a permanent presence in Canada. Ever since, TMCC and its affiliates have served the Canadian and North American mining industry from its head office in Regina.**

These days, Thyssen Mining is the trade name of a group of companies offering every aspect of underground mining and construction, including shaft sinking, ramp development and drifting, raise boring, electrical, mechanical and civil construction, grouting, ground freezing and production mining. TMCC remains one of the premier mining contractors in Canada and owns 70% of the CMAC-Thyssen Mining Group, a Quebec-based mining contractor and manufacturer of production drills and other mining equipment.

Since 1996, the work performed by TMCC for the uranium mines in Saskatchewan has been done through the Mudjatik Thyssen Mining Joint Venture, providing jobs, training and dividends to a dozen indigenous nations and communities of northern Saskatchewan. Since 2008, Thyssen has completed various major shaft sinking and construction projects for the potash industry through its 50% owned subsidiary AMC Inc.

Thyssen Mining Inc. services the United States of America and performs development and production mining, shaft sinking and the excavation of storage caverns for hydro carbons.

The Jetcrete North America and Sovereign-Thyssen Joint Ventures provide shotcreting and grouting services, respectively, throughout North America and beyond.

In addition, Thyssen Mining now offers steel erection services through its fully owned subsidiary Living Sky Industrial Inc. and steel fabrication and piping services through its

majority-owned company Northwest Fabricators Ltd. Both companies are based in Alberta and provide services to the Canadian oil, gas and mining industries.

TMCC's enduring catch phrase is Safety, Quality and Cost. We believe that each task can and must be performed without harm to people, property or the environment, and that no job is worth the risk of an injury. We consistently improve our safety performance and at the time of writing have not experienced a Lost Time Injury in 2 ½ years, but will not be satisfied or rest until the goal of zero harm is achieved. The quality of our work is what keeps clients coming back to us, and we pride ourselves in the large amount of repeat-business we have as a result. We realize that we have to provide value for money and are continuously looking to improve efficiency, though the implementation of new technology, hazard analyses and project controls.

Finally, and most of all, TMCC is defined by its employees. Many of our people have been with us for numerous years or have returned time and time again after projects were completed and subsequently replaced by new ones. They are proud of their achievements and always ready for the next challenge, to be safer, better and more efficient. They are dedicated, motivated, well trained, and they enjoy what they do. Each one of them is essential to who we are.

I kindly thank our clients, partners, employees and their families for choosing and supporting Thyssen Mining and hope that you will enjoy this brief overview of what we do.

Rene Scheepers



# The Thyssen Mining Group: THYSSEN SCHACHTBAU, Byrnecut Australia and TMCC Global partners for mining contracting and engineering

Primary resources are the basis of all our manufacturing industries. Increasing demand has resulted in the construction of increasingly complex mining installations that are placing growing demands on technology and operating methods. Shaft depths have increased (see paper by Opitz/Kratz in TS Report 2014/15) and this trend has been accompanied by ever greater specialisation. As a specialist mining company THYSSEN SCHACHTBAU GMBH (TS) has been involved internationally in this area for many years.

The company's Shaft Sinking and Drilling Divisions were set up nearly 150 years ago, in 1871, by August Thyssen. TS,

which developed from this early venture, was founded at the beginning of the twentieth century as an independently operating company. While in the early years TS traded solely as a shaft construction firm, its operations are now much more wide-ranging and in addition to mine development work the company carries out all kinds of drilling assignments, natural-resource projects and tunnelling ventures, not only in Germany but all over the world. TS has for many years also operated coal upgrading plants for the steel manufacturing sector.

TS currently employs a workforce of over 750, of whom about one third are engaged in operations in the home market. The

Ventilation system for the underground mine WS-10, Norilsk Nickel





Before the shaft visit

company has been a member of the VBS (German Association of Mining Specialists) for a number of years, thereby emphasising its close ties to the German mining industry. In 1947, when Germany was rebuilding after World War Two, the specialist mining companies operating mainly in the Ruhr coalfield region came together to form the VBS. And TS has maintained this old tradition through its membership of the Association. After some 70 years of VBS history TS is now the only specialist mining company still operating in the Ruhr area.

TS stands for tradition and partnership in the mining industry. But more than that it stands for reliability and quality as well as the development of innovative technology.

### ■ Thyssen Mining Group

The Thyssen Mining Group undertakes mining projects around the globe in association with TS subsidiaries in Germany, Russia, Kazakhstan, Austria, Bosnia and Macedonia and in partnership with its affiliates Byrncut Australia and Thyssen Mining Construction of Canada. The Thyssen Mining Group employs more than 6,500 people worldwide and generates a turnover of more than 1.5 billion euros.

These undertakings are still under the ownership of Count Claudio Zichy-Thyssen, who places great value on solidarity and mutual cooperation between his companies and has remained committed throughout his life to providing them with all the fervent and strategic support they need.

### ■ New shaft sinking ventures – six shaft construction projects currently under contract

Shafts are sunk to access underground deposits and are also used in civil engineering works and infrastructure projects.

The particular method employed for shaft construction will depend on the local geological formations and on the proposed shaft dimensions. During this selection process TS will advise the client on the technical options available and on the economic aspects of the project. TS has many years of experience in the installation of shaft lining systems and the company has its own engineering section with a staff of over 50 to undertake work of this kind. Shaft renovation and refurbishment are also part of the remit.

When using conventional shaft sinking methods, namely drilling and firing, it is essential to have a highly organised system in place for the individual working procedures. The various mechanical components that make up the sinking installation must also be very well coordinated for high sinking rates to be achieved. In addition, sinking performance will always rely on having a well practised and highly experienced crew on hand. In the case of the two Norilsk shafts, which are more than 2,000 m in depth, it was decided to develop a new type of excavation system specifically for this particular operation. With this new solution a fully lined shaft, complete with guide fittings and underground infrastructure, is installed above the shaft excavation machine after the sinking phase has been completed. This working method can achieve monthly rates of advance of as much as 50 metres.

### ■ Shaft sinking in water-bearing ground – cementation and ground freeze techniques

Cementation is used to seal the strata when working through stable, water-bearing formations. Examples of this technique include the shaft sinking projects at Norilsk (9 m finished diameter) and the two shafts currently being constructed for the Semmering Base Tunnel in Austria (250 m deep, 8 m in diameter).

Shafts in unstable, water-bearing ground can be sunk safely using the ground freeze technique. The development and monitoring of the freeze wall play a key role in such operations: continuous measurement data and computer-aided data analyses provide information on how the ice wall is developing in the individual geological formations/horizons. TS is currently involved in six freeze-shaft projects in Russia, where it has been given responsibility for managing, supervising and monitoring these shafts to their planned freeze depth of 820 m. Precise freeze-wall management is particularly important when dealing with shafts lined with cast-iron tubbings.



The freeze walls for the two SKRU-2 freeze shafts being sunk for the Russian potash producer Uralkali were started-off in the fourth quarter of 2016. These 400 m-deep potash shafts are scheduled for completion in 2020 and will be lined with cast-iron tubbing supports.

### ■ Shaft drilling in stable ground

Shafts in stable formations can be drilled at a high rate of advance with minimal strata degradation. The shaft cavity can be excavated true-to-profile using a mechanised shaft sinking machine. TS has delivered shaft sinking projects all over the world using rodless boring machines to widen the shaft from an initial pilot hole. The company has already sunk more than 60 km of shafts and staple pits 5.0 to 8.2 m in diameter in various countries around the world, including Germany, the USA, South Africa and Australia.

The shaft boring machine for shaft enlargement (SBE), which was developed in collaboration with Herrenknecht AG and Murray & Roberts RUC-Cementation, RSA, is capable of excavating shafts of more than 9.5 m in diameter.

### ■ Thirty years of constructing underground storage facilities for the safe containment of nuclear waste

TS started construction work on the Gorleben 1 and Gorleben 2 shafts in 1985. There then followed a continuous period of engagement by the client, the Peine-based company DBE (German Service Company for the Construction and Operation of Waste Repositories), that was to last right up to the present day. After non-stop activities aimed at exploring the Gorleben saltstock TS operations at the site terminated in 2016.

Konrad 1 and Konrad 2 shafts at the former Konrad iron-ore mine in Salzgitter are currently being converted and modernised to serve as long-term waste storage facilities. A great deal of expertise is available when it comes to the planning and construction of long-term roadway barriers and shaft seals; many structures of this kind were built for in-situ research and testing projects.

SKS-1 Shaft, Norilsk Nickel





View from the tubbing shaft bottom to the sinking stage

■ **Roadway development – more than 25 km of drivage currently under contract**

Mine roadways and excavations of all types and sizes are required in order to access and extract mineral resources. The specific function and routing of the roadway will play a key role in determining its layout and its length. Ongoing improvements in roadheading technology have ensured that high performance standards have been maintained in this area.

TS currently has commissions from clients in Germany and Kazakhstan to carry out mine roadway development work in areas with fairly complex geology. And the company is also engaged in roadheading projects in the Russian Federation. The current contracts cover more than 20 km of roadway and the methods being used include both conventional drilling and shotfiring as well as mechanised excavation with boom-type roadheading machines.

■ **The new Russian-based TEB drilling company represents a historically significant milestone for the development of our foreign operations**

The Moscow-based EuroChem company is a world-leading producer of mineral fertilisers. As EuroChem needs to undertake geological exploration on a vast scale a decision was taken to set up a joint drilling company with partner TS whose main activity would comprise the exploration of potash and phosphate deposits. The company, which has been named “Thyssen Schachtbau EuroChem Bohren” (TEB), was established in 2015 and has its head office in Kotelnikovo, a southern administrative district of Volgograd. It currently has a workforce of over 120 and is equipped with five deep drilling rigs.

Both shareholders are aware of the fact that while the launch of this Russian drilling company represents a milestone in the history of both companies it also means acknowledging responsibility for the local personnel and the commitment to carry out the drilling operations in an efficient and productive manner. Everyone involved appreciates that this will be a unique and difficult challenge. Moreover, it represents something above and beyond the usual corporate venture, for it involves opportunities and obligations that will cross borders and bring communities together.

■ **Exploration by surface drilling – more than 15,000 m of borehole a year**

Exploration drilling provides information about the content, value and formation of an area of deposits. Surveys of this kind serve as a planning basis for developing the deposits and extracting the mineral resources. The drilling data we supply make a valuable contribution towards improving the reliability and accuracy of geological assessments. TS currently has ten exploration rigs operating in the Russian Federation. These are engaged in exploring mining deposits at depths of as much as 1,700 m and in the drilling of mine infrastructure boreholes (diameter < 1,000 mm) and shaft pilot holes.

As well as supplying information about the strata, shaft pilot holes can also make life easier for the main shaft construction team by providing an opportunity for ground stabilisation using the latest injection technology, thereby paving the way for a fairly straightforward sinking operation.

Specific analysis work on the borehole results and drill cores, if available, can be carried out in close collaboration with the geophysicists in order to complete the geological data.



Infrastructure boreholes are created in order to transport stowing dirt below ground, but can also be used for the installation of supply pipes and waste disposal pipes (e.g. for power cables, fresh water, mine water, fuel, etc.).

The application of directional drilling technology reduces the number of surface collaring points and at the same time avoids having to drill through unstable beds, which is a time consuming process. Directional drilling allows several boreholes to be drilled from one site into preset target zones and three-dimensional linking can then be used to optimise the survey results.

### ■ **Underground exploration – effective and cost-efficient**

Horizontal boreholes up to 2,500 m in length that are drilled from sites below ground provide advance exploration data and help steer the mineral winning process. This kind of underground exploration is much more effective and cost-efficient than reconnaissance based on boreholes drilled from the surface. What is more, the content of the deposits is not reduced or narrowed down by the safety pillars that according to the regulatory authorities always have to be left in place around each surface borehole. TS is at present engaged in tough underground drilling assignments at the K+S KALI-owned Zielitz potash plant and at the Asse-GmbH mine facility, which is operated by the German Federal Office for Radiation Protection.

Turnkey construction and commissioning of shafts and mines The turnkey planning, construction, installation and commissioning of complete mining complexes are now playing an increasingly important role in company affairs. Two major contracts of this kind, namely the WS-10 and SKS-1 nickel mining projects, are currently being developed by TS.

The contract for the two SKRU-2 potash freeze shafts was essentially secured on the grounds that TS has the capacity to deliver freeze shafts on a turnkey basis from a single source. The project remit comprised not only the pre-cementation of the shafts in the overburden section and the TS-managed drilling of the shaft pilot holes and freeze holes but also the main sinking operation and simultaneous installation of the shaft support system, concluding with permanent decommissioning and sealing of the freeze holes after the freeze plant has been shut down. This broad spectrum of services was delivered entirely using TS-based resources, an achievement as yet unmatched in the global drilling industry.

### ■ **The Gotthard Base Tunnel was yesterday – now for the Semmering!**

In 2002 TS was contracted to provide various construction services at the Gotthard Base Tunnel, which at 57.1 km is currently the longest railway tunnel in the world. This involvement, which was to run continuously for the next twelve years, included shaft sinking assignments, drilling



work and the supply and operation of shaft winding equipment.

TS has now been engaged to carry out work at the Semmering Base Tunnel (SBT) in Austria and the company has signed a joint venture agreement with construction partners Implenia Austria and Hochtief Infrastructure (Austrian branch) that will see the completion of the SBT 1.1 tunnel section beneath Semmering Mountain. This project, which is expected to last eight years, includes not only the excavation of some 15.6 km of tunnel works and the drilling of a large number of exploration and reconnaissance holes but also the sinking of two surface shafts for the tunnel entrance close to the intermediate access. Operations commenced on 1st July 2015.

### ■ Planning and project handling

An internationally experienced team of engineers is on hand to work alongside the project departments on the following:

- planning alternatives with profitability calculations and analytical assessment criteria for optimised decision making
- detailed project execution schemes, including all the required technical equipment, structural plans and work schedules
- full-cost calculations for the project execution and proposals for financing options.

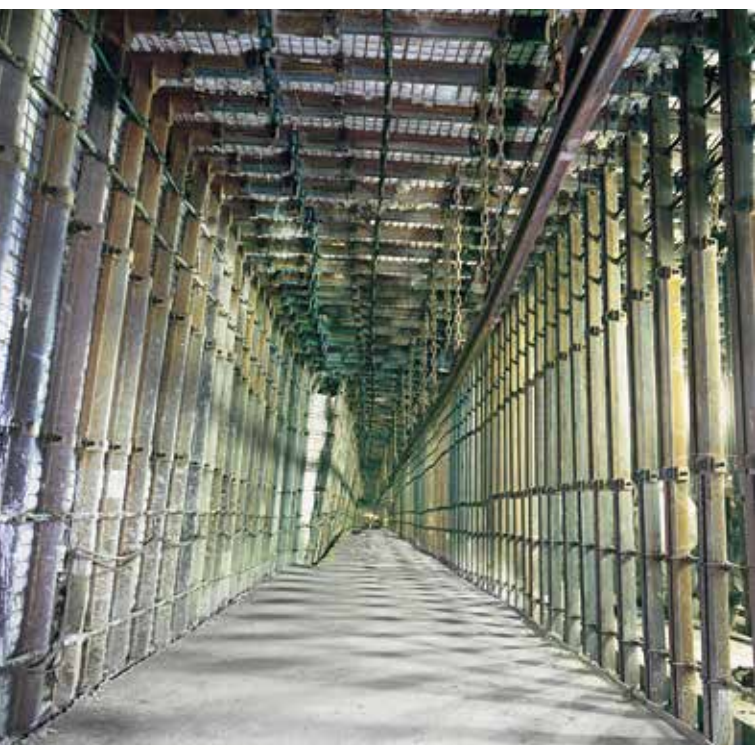

Armed with the latest CAD tools the Technical Office for Planning, Design and Calculation is fully equipped to meet the technical challenges imposed by a whole range of specific circumstances. The Technical Office also prepares verifiable documentation establishing proof of suitability and compliance with health and safety standards, as well as the documents required for official approval procedures.

### ■ Quality assurance and occupational health and safety

Our philosophy is to employ all the craftsmanship and professional working practices at our disposal, backed up by innovative technologies sourced externally or developed in-house, to fulfil all our commissions for roadway development, shaft sinking, borehole drilling and other construction work. Ensuring commercial success in these areas means delivering contracts cost effectively, on time and to a high technical standard.

The TS maxim is to avoid mistakes, not spend time rectifying them. And in order to reinforce this commitment we introduced the DIN EN ISO 9001-based quality management system – a wide-ranging family of standards that apply to all company structures and every member of the workforce. In addition TS is certified since 2016 according to DIN EN 1019 for the quality assured completion of steel supporting frames with document evidence of conformity.

TS remains committed to meeting the increasingly exacting demands of the market and of our customers as a way of confirming the high quality standards it has put in place. The ultimate objective of the company and its employees is to deliver construction and engineering services based on high quality workmanship, adherence to schedules and cost efficiency.

The internationalisation of TS sets more and more the focus on the transfer of the specialist mining business to countries outside Germany, and especially to the Alpine region, the Balkans and Eastern Europe. This strategic measure is aimed at compensating for the decline in orders from the domestic market. The realignment calls for professional competence, motivation and flexibility at all levels but also assimilates occupational health and safety into the corporate strategy right from the outset in order to ensure the company's long-term survival in the specialist mining market.

Given this strategic remit it was both logical and coherent to seek to extend and develop the existing safety management system, as based on the SmS standard obtained in 2004, to





include the Safety Certificate Contractors (SCC). This safety management system ensures that the quality of the health and safety standards in place is fully assessed at all company levels and improved as necessary. The safety certificate for contractors is a set of rules for a certifiable management system, combining as it does occupational health and safety with environment management.

SCC certification at TS, which has incentivised the workforce to adopt effective health and safety practices, will help to develop and cultivate occupational safety procedures well into the future. This will create real continuity in the implementation of strategic actions. The ambitious goal of 'zero accidents' therefore remains unchanged and will encourage our workforce to show total commitment in the pursuit of our objective.

### ■ Looking to the future

THYSSEN SCHACHTBAU GMBH is strongly placed to meet the challenges that lie ahead. Having a highly skilled and experienced team at our disposal is a crucial factor in all this, with the company currently engaged in executing a large number of major projects with timelines of between five and ten years. And state-of-the-art equipment is also on

hand to enable us to meet the high standards of quality and performance expected by our customers.

The integration of OLKO-Maschinentechnik GmbH, Olfen, into the THYSSEN SCHACHTBAU Corporation as a producer and supplier of shaft hoisting equipment, shaft sinking systems and hoisting winders has proved its worth. This strategic arrangement puts TS into the position to offer complete shaft sinking projects including development, supply, construction and implementation as a turn-key delivery with own capabilities and know-how.

TS is always ready to take on new projects for the mining industry. And by remaining true to our motto 'fully committed' we will also be delivering success for our customers and clients.

*Norbert Handke*

# THYSSEN SCHACHTBAU GMBH in the vanguard of occupational health and safety

Mülheim-based THYSSEN SCHACHTBAU GMBH (TS) has also been setting the international benchmark in the field of occupational health and safety. After two years of intensive preparation and training the existing Safety Management System, as based on the SmS quality seal issued by the BG RCI (German Social Accident Insurance Association for the Raw Materials and Chemicals Industry) in Heidelberg, has now been extended to include the SCC\*\*2001 Certificate for International Occupational Health, Safety and Environmental Management. This means that TS meets the requirements and standards applied by the international project sector in respect of industrial health and safety and environmental protection.

## ■ Introduction

For a specialist mining contractor engaged in carrying out high-quality shaft sinking, drilling and roadheading projects at both national and international level it is not just the expertise used in the performance of these operations that counts but also, and of equal importance, the health, safety and environmental standards achieved in delivering the services.

The Mülheim-based mining contractors TS have had the SmS seal of approval (‘system-oriented safety’) since 2004. This is equivalent to the international Occupational Health and Safety Assessment Series (OHSAS) 18001 Standard. In Germany the SmS quality seal is issued by the BG RCI (German Social Accident Insurance Association for the raw materials and chemicals industry) in Heidelberg and is designed to

promote trust and confidence among project clients, public authorities and other bodies. In the re-audits of 2008 and 2011 TS was able to demonstrate the continuous deployment of a systematic occupational health and safety management system.

When undertaking specialist mining work at the permanent underground waste disposal sites at Gorleben, Konrad and Morsleben, which are managed by the DBE (German Service Company for the Construction and Operation of Waste Repositories), SmS certification is essential when it comes to meeting the extremely high requirements imposed on occupational health and safety. And at Asse mine too, it was an absolute priority that in order to meet the specified health and safety standards the personnel deployed had to be trained to SmS certification levels.

Highly systematic processes and behaviour mechanisms implemented at management and operational level guarantee a high level of performance when it comes to industrial health and safety conduct. The quality seal of system-oriented safety (SmS) has adopted this behavioural pattern as its own. The system stipulates that intensive and regular process monitoring and employee training sessions are imperative if the SmS concept is to be maintained and kept fresh in the mind.

TS will not be resting on its laurels with the very high standards already achieved. For this reason, the company has taken a further step by imposing on itself the same wide-ranging safety requirements that are expected from contractors in the oil and gas production sectors and in the petrochemicals industry. The process involved in reaching this level of operational safety has once again mobilised and raised the awareness of every one of the 650 or so members of the TS Shaft Sinking and Drilling Division, with the result that the relevant behavioural patterns have been embraced in a more systematic and sustainable way.

Logo for SCC\*\* certification to ISO 9001







On-site audit at the Konrad Shaft joint venture project

### ■ The THYSSEN SCHACHTBAU safety management system SCC\*\*:2011 as a part of corporate strategy

The internationalisation of TS that was begun in 2002 sought to transfer more and more of the specialist mining business to countries outside Germany, and especially to the Alpine region, the Balkans and Eastern Europe. This realignment not only called for professional competence, motivation and flexibility at all levels but also incorporated workplace safety into the company strategy right from the outset in order to ensure that the reorientation was both successful and sustainable and to guarantee the company's long-term survival in the specialist mining market.

Given this strategic remit it was both logical and coherent to seek to extend and develop the existing safety management system, as based on the SmS standard obtained in 2004, to include the Safety Certificate Contractors (SCC). As well as improving the company's competitive position this move would at the same time constitute another step towards greater legal certainty. The quality of the health and safety standards in place was to be extensively assessed at all company levels, improved as necessary and then certified following the successful implementation of the scheme.

The certification process applied by the Cologne-based TÜV Rheinland Cert GmbH will incentivise the workforce to adopt effective health and safety practices in all national and international mining activities. As the only mining contractor to carry the SCC\*\*:2011 certificate TS will therefore play a leading role as a promoter of workplace safety in the national and international mining sectors.

The safety certificate for contractors is a set of rules for a certifiable management system, combining as it does occupational health and safety with environment management.

### ■ The HSE handbook

Every process that is examined as part of the SCC Management Audit is described in the TS HSE handbook (Health, Safety and Environmental Protection). This manual has been drawn up in accordance with the normative rules of the SCC and it reflects the efforts being made by the company to set very high standards in this area. The handbook is accessible to every member of staff and its recommendations are binding. All managers and staff members are required at all times to abide by the legal regulations and operational guidelines that apply in respect of workplace safety and environment protection. They have to protect their own health and that of their fellow workers and in everything they do they must also ensure that environmental pollution, accidents and work-related illnesses are prevented as far as possible or at the very least kept to a minimum. It is the remit of every manager to take responsibility for occupational safety, health and environmental matters (transfer of duties) and the executive committee undertakes to provide the necessary means and resources for this.

### ■ HSE project planning

Projects that entail project-related HSE requirements and agreements are given a client-coordinated project plan for target tracking purposes. The site manager remains responsible for all coordination and consultation dealings with the client throughout the duration of the project.

If subcontractors and recruitment agencies are required to ensure the success of the project these have to be given instructions on the content of the HSE requirements before commencing work. The managers of these firms and agencies are to be provided with all the necessary information so that their personnel can be instructed accordingly.



On-site safety audit of underground exploration drilling work at Asse Mine

### ■ Staff qualifications

SCC certification requires each and every company employee to be fully trained and therefore differs in this respect from the SmS certification. According to SCC certification requirements more than 90% of the operational staff of TS must be trained and tested to appropriate safety standards. The systematic assessment and training of the workforce requires a huge amount of effort and company employees have to be supervised on an ongoing basis not just when working in German mines but also when carrying out shaft sinking, roadway drivage and drilling operations in Austria, in the Balkans and in Switzerland, as well as in Russia and Kazakhstan. The introduction of the SCC health, safety and environment management system was accepted without reservation by the working teams involved. The operative managers were tested and assessed by TÜV Rheinland as part of the certification process. A procedure was also introduced in conjunction with TÜV Rheinland aimed at ensuring that the appropriate professional qualifications were in place. A personalised safety pass will henceforth be assigned to employees that will apply throughout their working life in the same way as the personal log-book that was traditionally issued to mineworkers. The safety pass records all the individual instruction courses and training programmes that the holder has completed and the testing

and certification process will remain valid for a period of ten years. Refresher training courses are held every year for staff from the occupational safety and works medical departments. In addition, only those subcontractors and recruitment agencies that verifiably operate a fully functional HSE scheme will in future be included for project deployment.

### ■ Progress reports, monitoring and control

The strategic launch of the HSE management system is clearly a statement on the part of the company that it attaches real importance to having a safe, healthy and environmentally sound workplace for all its employees. Monthly inspection reports from the senior management level and operational management level are a mandatory requirement. The inspections cover various themes so as to include as broad a range as possible. The inspection reports and annual progress reports from the safety department and works medical officer form part of the management review. This approach ensures that an effective system is in place when it comes to effectivity checks.

### ■ Accident statistics

The procedure that TS uses to record and analyse accidents has been extended to include near-miss incidents. Last

Site audit at the SBK (Kazakhstan Shaft Construction) Donskoi GOK mine







Site audit at the SBK (Kazakhstan Shaft Construction) Donskoi GOK mine

minute risk analyses' (LMRA) are now carried out immediately before starting work.

The agreed standards define thresholds for the accident frequency rate and place accident statistics at the centre of the evaluation. Every accident is entered in the accident statistics from the first day of incapacity (SmS from the third day of incapacity). The SCC thresholds that have to be met in order to maintain the validity of the certificate are specified within very narrow limits and are based on the respective BG accident frequency statistics.

The TS figures for accidents resulting in more than one day of incapacity have shown positive trends in recent years and while in 2012 there were 4.75 accidents recorded per million hours worked this improved dramatically to zero accidents recorded per million hours in 2014. The projected accident target was therefore achieved, in line with expectations.

### ■ Environment protection

Waste prevention lies at the heart of TS's environmental philosophy. The best way to protect the environment is to avoid waste and conserve resources. The main concern is therefore to prevent environmental degradation and to minimise the environmental impact through the efficient use of materials and equipment. Operating material has to be sourced from suppliers, as the company does not manufacture any products of its own. The company's prime objective during construction and assembly work is therefore to protect and conserve the environment and to eliminate negative

environmental factors by way of environment-friendly fabrication and assembly techniques. All the materials used are identified and their environmental impact is assessed. If necessary, appropriate preventive measures are taken in order to rule out negative environmental effects.

### ■ Conclusions

For TS the SCC\*\*:2011 certification means taking a holistic view of occupational health, safety and environment protection measures. This new set of company practices, which are based on the HSE handbook, are binding for all and can be seen as a guarantee for trust-based cooperation both within the company as well as with clients and subcontractors.

The systematic training of management and staff, combined with countless effectivity checks, underlie the long-term success of the HSE management system. These measures make a huge contribution to the company's positive business development and to the safeguarding of jobs at TS.

*Markus Westermeyer*

# Ibbenbüren colliery – anthracite coal with international reputation

**Ibbenbüren colliery, which is operated by RAG Anthrazit Ibbenbüren GmbH, is one of only two RAG-managed coal mines still in active production in Germany. The colliery is located in the Ibbenbüren coalfield near the town of Ibbenbüren, which is part of the municipality of Mettingen in the Tecklenburg region. Ibbenbüren colliery produces anthracite exclusively, which is typically used as steam coal and for household fuel. The mine's north shaft, which extends to the 1,545 m level, is the deepest shaft in Europe. The people of the region identify with the colliery and have an extremely close attachment to it.**

The coal produced at Ibbenbüren is mainly used for generating electricity at the adjacent RWE-run Ibbenbüren power station. Some fuel is shipped by rail or waterway to other power stations in the area, and some is sold to the non-subsidised heat market. Sized anthracite is also used in small domestic fuel appliances and in large commercial heating systems to supply heat to greenhouses and swimming pools. Approximately one third of the sized anthracite is shipped to nearby countries for the same purpose. The consumption in the household fuel market is approximately 300,000 tonnes a year.

Ibbenbüren anthracite is an ideal material for water treatment and purification and it is used in waterworks, in small-scale clarification plants and in specialized water filters for development aid projects. When processed into activated

Oeynhausenshaft Ibbenbüren, aerial photo



carbon it is extremely effective at removing chlorine, trihalomethanes and general oxidisable substances from water. The coal is also used for producing carbon electrodes, for carburisation and for slag foaming in the steel industry.

## A brief history of the colliery

15th/16th century	First signs of coal mining in Ibbenbüren
1747	Dickenberg and Buchholz mines under Prussian control
1770	Establishment of the Tecklenburg-Lingenschen mining authority
1920	Modernisation of the Schafberg haulage system and take-over the colliery by Preussische Bergwerks und Hütten AG
1942	Invention of the coal plough at Ibbenbüren colliery
1958/1960	Colliery production exceeds 2 million tonnes for the first time
1979	Closure of Westfeld mine
1999	Preussag is taken over by Deutsche Steinkohlen AG. Operating company: DSK Anthrazit Ibbenbüren GmbH
2008	The company is renamed RAG Anthrazit Ibbenbüren GmbH.
December 31st 2018	Planned end of coal production – colliery closure

## Active mine shafts

	depth	function
v. Oeynhausenshaft no. 1	414.90 m	materials winding shaft
v. Oeynhausenshaft no. 2	339.30 m	no headgear, periodic pumping
v. Oeynhausenshaft no. 3	868.00 m	main winding shaft, 4 skips
Theodor shaft	603.30 m	main ventilation shaft
North shaft	1,545 m	main manwinding and materials shaft
Bockradenshaft	391.10 m	ventilation shaft



**Ibbenbüren**

Colliery personnel as of 1 July 2016	1,500 MS
Annual production:	approx. 1.3 mill. t saleable
Average working depth:	1,323 m
Max. Depth:	1,600 m
Mining concession:	92 km <sup>2</sup>
Roadway system:	69 km

**THYSSEN SCHACHTBAU on-site operations**

TS personnel have maintained a continuous presence at the colliery since 2009 and have been engaged in activities such as roadheading, working inbye on main-gate and tail-gate drives and undertaking roadway dinting and repair tasks. TS is therefore providing a full range of services as a specialised mining contractor.

TS is continuing to make a significant contribution towards the development of seams 54 and 53 in the Beust work area. The Beust panels form the most westerly block of the mine's 'East District' and are named after the Beust shaft that is located in this part of the take. The Beust shaft itself takes its name from the Prussian chief supervisor of mines Ernst August Graf von Beust, who was responsible for the Ibbenbüren coal mines. Work started again in the Beust district in January 2012, the first time coal had been won in this area since the 1950s.

**Driving the last roadways at Ibbenbüren colliery**

The last roadways to be driven at the colliery were '10 north' in seam 53, the western main seam road '6/7a east' and its



Conventional roadway drivage with blast hole drilling

connecting drivage '7a east' in seam 78. The contract to excavate these drivages was awarded to TS. Seam 78 will be the last coal seam to be worked at Ibbenbüren, where coal mining will continue until 2018.

**Key roadway data**

	length	cross section
Roadway '10 north', seam 53	1,200 m	30.8 m <sup>2</sup>
Western main seam road '6/7a east', seam 78	245 m	30.8 m <sup>2</sup>
Roadway '7a east', seam 78	700 m	30.8 m <sup>2</sup>

In line with standardised roadheading and support setting rules, the roadways at Ibbenbüren colliery are generally constructed using type-A combination supports with full backfilling.



Longwall mining – plough face



Construction of a roadway junction

The actual drivage operation is carried out exclusively by conventional drilling and blasting. Roadheaders are not used because of the high risk of gas outburst.

Since January 2015 TS personnel have been operating in the coal production zones around the main-gate and the tail-gate drives. Work in these areas includes:

- Supporting the stable-hole with hydraulic props and timber props
- Securing the face-gate intersection
- Building and filling the roadside pack

The impressive results of the weekly quality checks attest to the high standards that these operations have achieved to date.

Dinting operations in areas affected by severe floor convergence along with roadway repair work in various parts of the mine complete the picture of how TS has been working hand in hand with colliery personnel.

### ■ Summary

Looking to the future, we are very pleased to have been actively involved in underground operations at one of the German coal industry's last two production sites. Our priorities on this project, as in all projects carried out by TS, have been to ensure safe working conditions for everyone involved and to meet or exceed the highest of standards in the quality and execution of our mining works.

*Arno Lehmann  
Dr. Axel Wejßenborn*



Northshaft 1 Ibbenbüren  
aerial photo



# Driving deep-level face headings with specialized support technology at Prosper-Haniel colliery

In 2009 development work started at Prosper-Haniel colliery with the goal of accessing the coal reserves of Zollverein 1/2 seam in the Prosper North district. This strategic undertaking was necessary in order to secure future coal production at the mine until the end of 2018.

The coal seams, which had a maximum thickness of 4.65 m, were to be equipped with ,group C' shield supports with a setting range of 2.4 to 5.2 m.

Both the planning and the execution of the face heading operation presented significant challenges for all of those involved with the project.

From 2013 to 2015 THYSSEN SCHACHTBAU GMBH played an integral role in the project, successfully developing face headings 123.8 and 121.8.

The planning for coal winning operations in the Prosper North district focused on three working zones of equal size to be created, namely coal panels 121, 123 and 124. These panels were located at a depth of 1,200 to 1,250 m below the pit-

bank level. The haulage and ventilation areas were to be connected to the production area through the western main seam roads E550 and E551, the ventilation borehole G248 and the rising stone drift D348, which serves as the return air route for mine level 6. Both G248 and D348 were previously developed by TS.

## ■ Planning

Some of the challenges involved with this project in terms of timeframe, support design and machine technology can be understood by examining the following design requirements:

- Excavation of an underground cavity measuring approximately 10 m in width by 5 m in height to accommodate ,group C' shield supports
- Selection of high-performance machine technology and combination systems capable of responding flexibly to the particular demands of the project, which include geological faults, gas exploration drilling, large seam thicknesses and a variety of roofbolting methods.

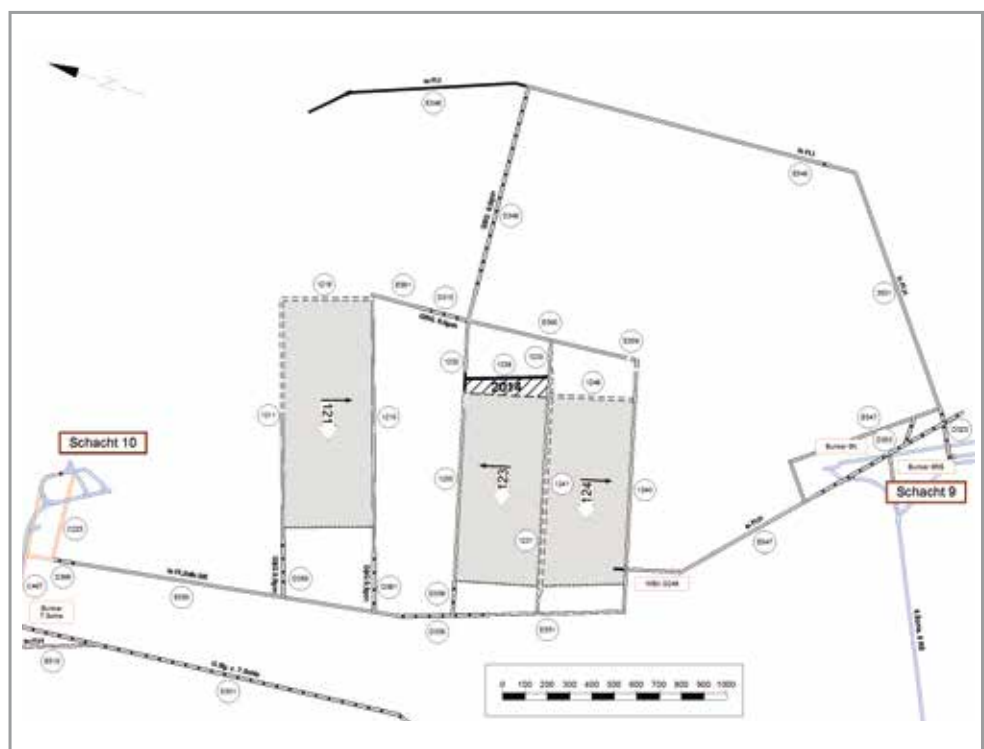

Layout plan for the Prosper North district, Zollverein 1/2 seam



Group C shield support

- Development of a support system that could offer sufficient support under the prevailing operating conditions.

After extensive calculations and variant comparisons the following parameters were selected for the excavation of the two face start-up headings:

- Excavation by drilling and blasting
- Deployment of type-A combination supports
- Excavation of a preliminary heading with a floor width of 7 m, to be widened to approximately 10 m with a parallel entry
- Placing of two rows of TH (Toussaint-Heintzmann) props to increase support stability
- Installation of retainer bolts for additional ground support for the equipping phase

### Roadheading technology

In order to meet the technical requirements and accommodate different heading width and ground support requirements during the development phase, a BTRK 2E twin-boom electro-hydraulic jumbo was selected for the pre-heading and a single-boom jumbo was selected for the parallel entry. In both cases the back-up systems included a K 313 S loader, an AMG 10200 multifunction work basket and a pontoon working platform.

The roadheading equipment was backed-up by various manually operated drilling tools so that the load-bearing and holding bolts could be installed in accordance with the technical specifications.

Each heading was equipped with three 120 m-long PF1/500 chain conveyors for the removal of the blasted rock material.

Technical data	
System width:	1.75 m
Setting range:	2.4 to 5.2 m
Support resistance:	approx. 1,100 kN/m <sup>2</sup>
Load bearing capacity:	approx. 11,000 kN
Shield weight:	approx. 38 t

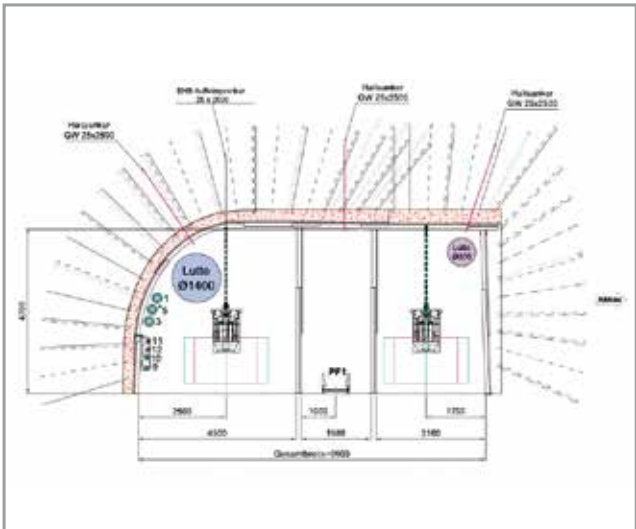

Support pattern for the preliminary heading

Support pattern for the pre-heading and parallel entry

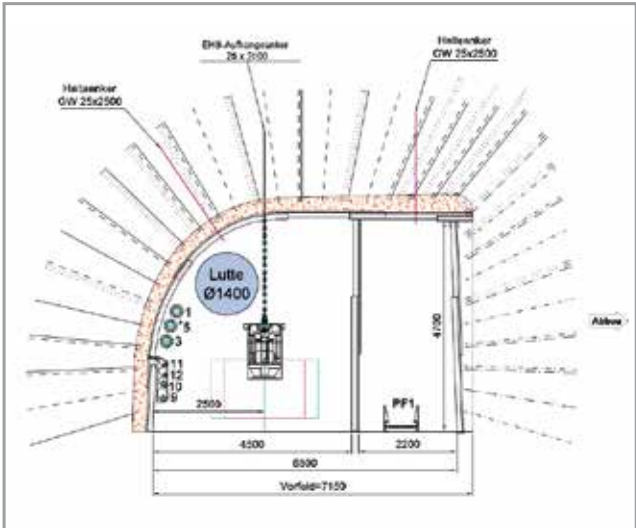

### Heading Work Face heading

The 123.8 and 121.8 face headings were driven in an almost identical manner. Once the branch entries had been completed, a section of preliminary drift was driven to a length of approximately 15 m using rockbolt supports. The heading work was then put on hold so that the steel supports, backfill and auxiliary bolts could be installed over a distance of approximately 12 m. With the branch entry area stabilised early in the operation it was then possible to prepare for the



installation of the two working platforms. The availability of the multifunction basket after 20 m of advancement and the arch setting platform after approximately 30 m of advancement meant that the drift was fully equipped and ready to go.

The deployment of the mechanical pontoon platform meant that development could be advanced both in the direction of the roadhead and away from it. On the inbye side it was therefore possible to set the centre props following behind the drivage, while at the same time the arch supports could also be installed in the outbye direction. As a consequence, the need to employ the working platform as a standing surface for the backfilling work and for the installation of the load-bearing and retaining bolts meant keeping the working cycle organized was essential.

Roofbolt supports in the pre-heading

Seam outcrop in the parallel entry

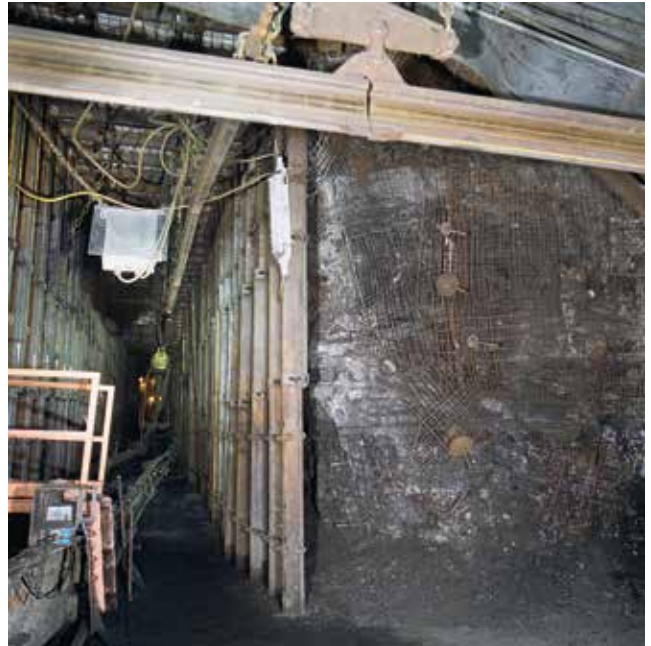





Working platform set up as a pontoon



Excavating the parallel entry with the aid of a safety screen and roofbolting platform



Outbye support system in place

Parallel entry with support system fully in place

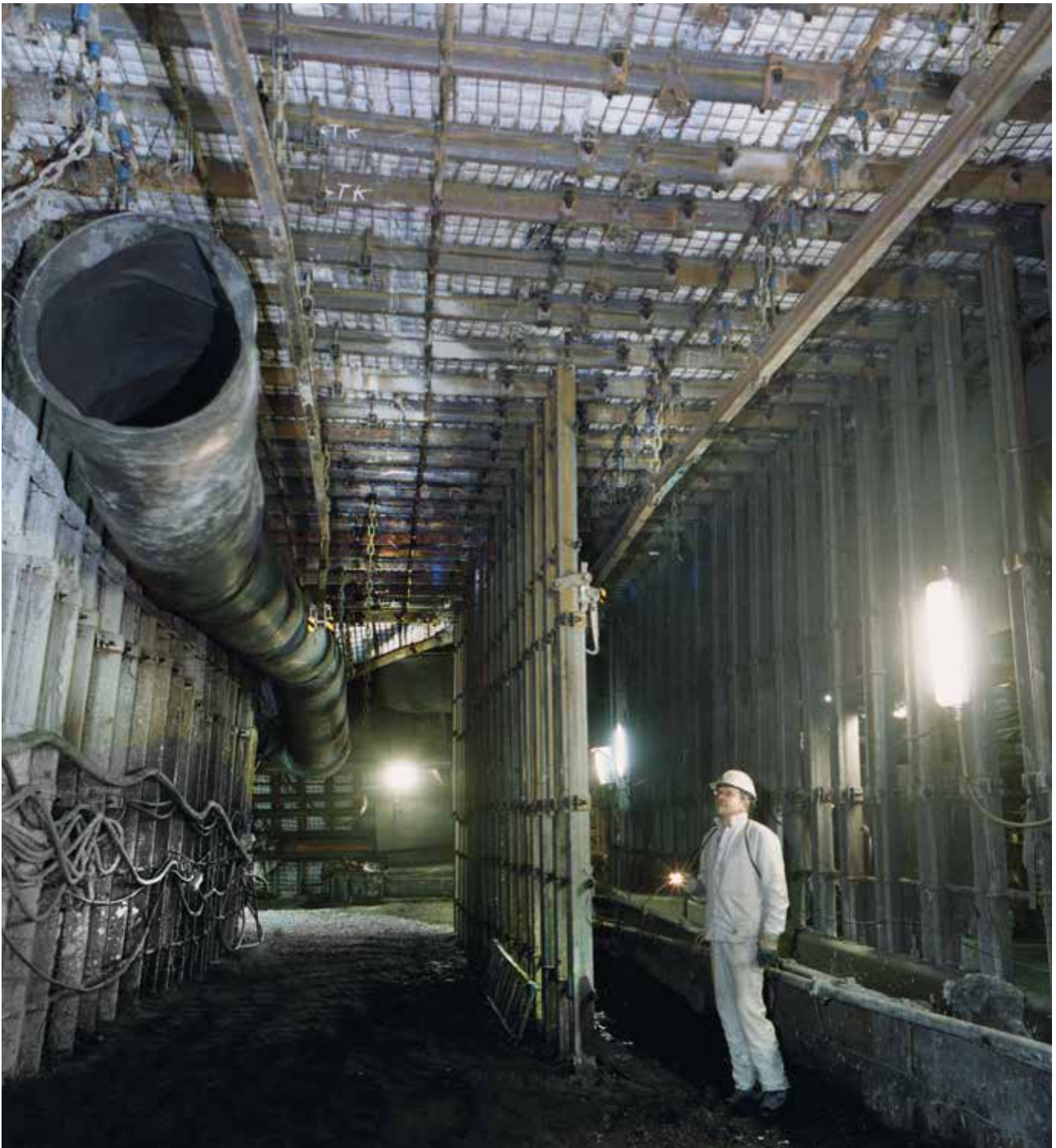





Entry track in the pre-heading has been set up and is ready for manoeuvring the shield units

Work on the parallel entry behind the main heading only began when the main heading had been completed to a distance of approximately 150 m. The approach adopted here was the same as the approach used in the preliminary heading, with the steel supports being installed with minimal time lag. In order to protect the air ducting and the other roadway fittings from flyrock, it was necessary to install blasting mats between the rows of supports. The blasting mats were made from lengths of belt conveyor bolted together to form a curtain. The mat was attached to roller mountings fitted to a rail so that it could be deployed quickly and easily using an overhead trolley.

Complex tectonic conditions and the convergence movements resulting therefrom meant that the progress achieved in the two headings differed quite considerably.

Panel 123 encountered several geological faults that required additional exploration drilling and a more elaborate rockbolt system. The position of a particular geological fault running

Complete shield unit at the face entry point







Shield in its final position

View of fully assembled face installation



parallel to the drivage meant that after the heading had been completed the floor level had to be adjusted based on the line of the fault. By casting the floor of the parallel entry in concrete it was possible to ensure a trouble-free start-up for panel 123.

Both face headings were constructed on time and to a very high standard.

### ■ Face equipping operation

After heading 123.8 had been completed TS was selected to assemble the face conveyor and install the shield supports as part of the face equipping operation.

The operation to install the face equipment meant having to manoeuvre the shield units into place in the pre-heading and then moving them up against the face conveyor in the parallel entry. Because of their size, the supports first had to be stripped down into smaller individual sections before they could be transported down the shaft and stored for reassembly at a special installation area. The complete shield units were then transported one by one on a special trolley to the face entry point. Here the job of the TS team was to remove the centre props in the entry zone, manoeuvre each shield unit into place and couple it up to the face conveyor.

The face equipping work was completed on schedule and to a high standard. In November 2014 the client was able to commence coal winning in panel 123 as they had planned. Panel 123 has since been exhausted and the operation to transfer the face installation to panel 121 is now nearly complete.

### ■ Conclusions and outlook

Meticulous preparation in planning and executing of the pilot project ,face start-up heading 123.8' proved to be a vital factor for the success of the operation.

The valuable experience acquired in panel 123, both when driving the heading and when installing the face equipment, also proved its worth during operations in panel 121.

The high quality of the coal-face development and equipment installation work has further added to THYSSEN SCHACHTBAU's reputation as a reliable partner and specialist contractor in the mining industry.

*Ulrich Barth  
Reinhold Albersmann*





## The Donskoi GOK project: status report on roadway drivage operations under difficult strata conditions

The client TNK Kazchrome is one of the biggest producers of chromium ore in the world. The company, which has some 19,000 employees on its books, plans to increase the annual output from its two mines (‘Molodeshnaya and ‘Tenth Anniversary of Kazakhstan Independence’) from 3.7 million tonnes to 6 million tonnes of ore by 2020. In order to achieve this target the company assigned the Donskoi GOK project to T00 Shaft Sinking Kazakhstan, which was set up by the two parent companies THYSSEN SCHACHTBAU GMBH and SCHACHTBAU NORDHAUSEN.

### ■ Demands on the roadheading technology

The in-situ rock mainly consists of gabbro and amphibolite interposed with medium to highly jointed serpentinite. The

severe jointing means that the rock structure is for the most part of low strength. The roadheading technology would have to meet particularly high safety and performance requirements if it was to overcome the difficult rock conditions.

Mechanised drilling and firing was preferred as the basic operating technique as it could respond quickly to rapidly changing strata conditions. In order to ensure this capability a combined support system was employed comprising mesh support arches, steel-fibre shotcrete and rockbolts. The machines selected for the operation also had to be compact enough to operate within the relatively small roadway cross section of 14.8 m<sup>2</sup>. The equipment ultimately chosen for the task was as follows:

- Atlas Copco Rocketboomer 282 twin-boom drill jumbo with telescopic drill feeds

Donskoi GOK: The winding shaft (start point) and the ventilation shaft (end point) are some 4.5 km apart



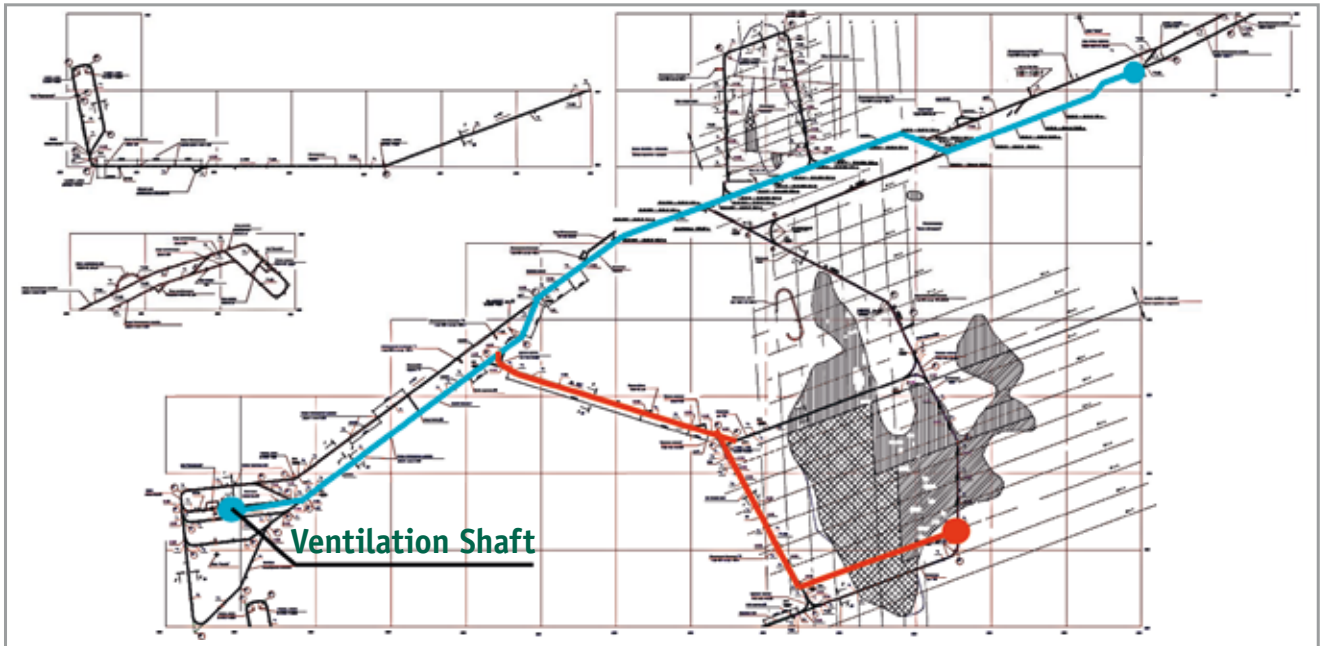

Roadway plan for the -480 m-level (900 m below ground level)

- Terex-SCHAEFF ITC 120 F4 tunnel heading and loading machine with chain conveyor and loading table
- shotcreting unit comprising two MEYCO Oruga shotcrete manipulators and two MEYCO Altera concrete pumps
- three Mühlhäuser concrete remixer each of 3.1 m<sup>3</sup> capacity
- Hartman HA MP 1125/750 S stationary concrete mixing plant.

The high heading rates meant that the concrete pumps and remixer had to operate permanently at the limit of their performance, which resulted in high levels of wear and tear. The situation was greatly improved with the procurement of two additional concrete remixer and a larger Putzmeister P 750 concrete pump. This halved the amount of time needed

Breakthrough to the ventilation shaft



to apply each batch of shotcrete, which significantly increased the rate of advance. Another improvement was introduced by switching from steel fibres to polymer fibres in the shotcrete. The benefits of this decision were soon apparent in the form of a reduced maintenance requirement and less mechanical wear and tear at the concrete pumps.

### ■ Auxiliary ventilation for the drivage

The supply of fresh air over the entire length of the drivage posed another challenge. As the excavation had still not broken through it was clear that a special ventilation concept would have to be developed. After a detailed examination and measurement of the site a suitable ventilation scheme was developed in collaboration with CFT. The key problem lay in the fact that the entire drivage required an auxiliary ventilation system extending right up to the breakthrough point with the ventilation shaft. Consequently the decision was taken to use exhaust fans positioned as close as possible to the roadhead to cover the entire length of the drivage and deliver the waste air into the existing air flow via twin air ducts. For the system to work the fresh air had to be speeded-up using additional fans that could also ensure an effective dispersal of the shotfiring fumes at the roadhead.

### ■ En route to the breakthrough

A total of 3,100 m of roadway drivage have been completed since the operation commenced in August 2013. The accompanying plan shows the progress of the heading to date. The first 800 m were typically driven through rock that





Roadheading team celebrate the breakthrough to the ventilation shaft in the company of visitors from home

varied from moderately difficult to challenging. As the drivage advanced the geological bedding conditions of the in-situ rock became increasingly faulted and disturbed, with the result that the middle section of the roadway between the two ore deposits proved extremely difficult to deal with over a length of some 600 m. The profile collapses caused by the friable rock were subsequently and very effectively controlled using an advance support system based on injection rockbolts set into the roof strata. After a further 1,700 m of drivage through highly inconsistent lithology the welcome breakthrough to the ventilation shaft was finally achieved.

During the three-year lifetime of this connecting drivage project the main focus of attention was directed at achieving the first milestone objective, namely to create a link as quickly as possible between the winding shaft and the ventilation shaft at the 480 m-level, thereby greatly improving the supply of fresh ventilating air across the entire horizon.

The later stages of the operation saw performance rates of as much as 150 m a month achieved on several occasions. In fact the performance choke point was not the roadheading technology but rather the capacity of the winding shaft.

### ■ Follow-up contract and future prospects

Both the client and the parent group were extremely satisfied with the results achieved by SHAFT SINKING Kazakhstan in the course of the project.

With the breakthrough successfully completed the roadway will now be continued in a southerly direction ,to drive around the ore deposits'. The signing of a follow-up contract has now given the starting signal for the second stage of the overall project, which involves a challenging 4,000 m of development drivage.

TOO SHAFT SINKING Kazakhstan now sees huge opportunities for more contracts of this kind. The client is planning to construct an underground roadway network some 12 km in length on the 480 m-level. Another ore extraction horizon below the 560 m-level also offers great potential for further development work.

*Eugen Hoppe  
Sergej Hübscher  
Eduard Dorn*



# Mining for Barrels – an innovative storage solution Robinson Butane Cavern project

**In order to provide a safe, long term storage solution for the Company’s liquid butane, without the inherent drawbacks typical of above ground tanks, Marathon Petroleum turned (for a second time) to solution-oriented THYSSEN MINING (TM). Together with WSP-Parsons Brinckerhoff, TM is rising to the challenge to create a modified room and pillar underground storage cavern to complement Marathon’s Robinson, IL US refinery operations.**

As a result of TM’s 2012 success with salvaging Marathon’s Catlettsburg Cavern (a project started earlier by another contractor), TM was the first contractor called when a second cavern was being considered. A new cavern complex with a 1,400,000 barrel (222,500 m<sup>3</sup>) design volume was desired in southeastern Illinois (US) at Marathon’s Robinson Refinery. This region proved to have an acceptable 27 m tight-shale horizon located at a reasonable 185 m depth from the surface. Geology like this is ideal for the pressurized storage

Surface Set-up





required for liquid petroleum (LP) products such as butane and propane.

Planning began in Q1 2014 and Thyssen was able to bring together lessons learned from Catlettsburg and optimize a design to increase efficiencies. A unique challenge was to economically design infrastructure adequate to support a full scale mining operation, yet maintain a “temporary” nature knowing that, after two years, all of the surface and underground fixed works would be removed. The layout of the cavern consists of a single level of lateral drifts and cross-cuts (6 m W x 8.5 m H) arranged in a “hatch” pattern, separated by pillars, and covering a diamond shaped 3.7 ha footprint. The access shafts are in the center and will later serve as submersible product pump wells.

Three shafts were blind bored to 200 m depth and provided with steel liners: A 2.4 m dia. service shaft for personnel/material conveyance, a 2.4 m dia. production shaft for excavated rock skipping, and a 1.8 m dia. fresh air ventilation shaft. Utilities were developed, headframes and hoists installed, and all the temporary facilities were established in, what was a few months earlier, just a cornfield.

Breakout drift mining from the shafts started in Q2 2015 and involved a necessarily slow, methodical approach using jacklegs and manually shoveling rock into 2 m<sup>3</sup> skipping buckets. Once enough room began to be established, progressively larger equipment could be mobilized. Shovels and blow pipes were replaced with a slusher, then a small skidsteer loader was brought down – a happy day for the miners. The first drifts were 2.4 m x 3.0 m and connected all three shafts so that a preliminary pressure test could be conducted to verify geological integrity.

The underground infrastructure was then constructed. An automated skip loading pocket with a rotary rock breaker was installed at the production shaft station. With breakout mining complete, underground equipment was mobilized. Two-boom jumbos, mechanized bolters and 3 m<sup>3</sup> LHD's make up the main fleet. Recall that all this equipment had to fit down a 2.4 m diameter shaft and often there were only mere millimeters of clearance. Careful logistics planning is paramount with such access constraints.

Production mining is done in two passes, a top cut and then a bench cut. Roof support consists of fully resin encapsulated #7 x 1.8 m threaded rebar with a 1.2 m x 1.2 m pattern spacing through wire mesh. The robust support is desirable to achieve a 50+ year service life. Cavern entry for maintenance is not an option after LP product is stored so it has to be right the first time.

An on-site labor force totaling 74 employees, comprised of support staff and three mining crews, executes the work. Mining the top cut, working up to ten active headings, has been able to achieve an average of 3,856 barrels/day (613 m<sup>3</sup>/day). This will transition into mining the bench during Q4 2016. Excavated shale is skipped to the surface via a 5 m<sup>3</sup> skip and land applied at the project site to a depth of 4.5 m, which will later be reclaimed. Mining excavation is forecast to be complete Q3 2017.

Feeding the Crusher





Installing Ground Support

The project will then begin the cavern conversion phase whereby the shafts are fitted with process equipment. To start, everything that is not ground support must be removed from the cavern. It is imperative that even the smallest things (down to ear plugs and candy wrappers) be removed so that the LP product pumps do not get plugged. The three shafts are fitted with pressure domes at the surface, configured for submersible pumps at shaft bottom.

A final pressure test is conducted for the entire excavation. Nitrogen is used for the test and it also functions as a purging gas to displace the oxygen atmosphere; dozens and dozens of nitrogen trucks are required. LP can then be transferred into the cavern with a target start of Q2 2018.



Job well done

This project is an example of how important it is to partner with a client to safely deliver a quality service and build a lasting relationship. Because of the careful work done to help Marathon salvage a tenuous project earlier, when a new cavern project was conceived, Thyssen Mining was called back without hesitation. We will continue to strengthen our knowledge base and skill sets to become a leader in this unique market of developing LP storage caverns.

*Ryan J. McHale*





Bulyanhulu Jumbo

## ByrneCut Offshore Tanzania Ltd. increases advance rate at Bulyanhulu Gold Mine considerably

**The association between ByrneCut and the Bulyanhulu gold mine goes all the way back to 1999, when ByrneCut secured their first international mining contract with the Kahama Mining Company. The development contract spanned nearly 5 years when the company transitioned to owner mining taking on the decline and lateral development themselves. Today, ByrneCut is contracted to Acacia Mining to complete a package of critical development under another 5 year mining agreement.**

The Bulyanhulu underground gold mine is located in the north western corner of Tanzania in the Kahama district which is 150 km southwest of Mwanza; an active gold mining region in Tanzania.

The mine has both shaft and decline access and the current life of mine is estimated by Acacia to be more than 30 years. The currently active development workings are as deep as 1,400 m below surface and thus as you can imagine, managing the heat and supply of primary ventilation are critical factors in the efficient operation of mining underground at

Bulyanhulu. Fortunately, the ground conditions are typically good with minimal ground water or movement encountered. It has a series of narrow vein, steeply dipping orebodies and historically small drive sizes have been utilised to access them. The mine is currently transitioning to a mechanised production mining method of longhole stoping. And this is

Bulyanhulu Operations at night





2016 Bulyanhulu Underground Gold Mine

Mine	Bulyanhulu Gold Mine, Tanzania
Owner	Acacia Mining Plc
Scope	Decline and lateral development, excludes production.
Contract Tenure	5 years to December 2018
Contract Type	Alliance with Key Performance Indicator (KPI) Modifier
Mining Method	Development - Mechanised drill and blast, loading and hauling
Ground Support	2.4m galvanised split sets and mesh with cable bolts as required
Development Metres	Contract Total 60 km
Production Tonnes	Production by owner, 240 ktpa development ore
Manpower	60 Expatriates and 218 Tanzanians
Major Equipment List	Development drills 5 x Sandvik DD420/DD321 Twin Boom Jumbos, 6 x Sandvik DD210L Single Boom Quasars Loaders 4 x Sandvik LH514, 4 x Sandvik LH307, 1 x Toro T6 Trucks 3 x Sandvik TH540, 2 x Sandvik TH430, 3 x Atlas MT436B

where Byrncut has been able to offer significant value to Acacia by introducing their high speed fully mechanised method of larger sized development to increase monthly advance with the existing fleet of mining equipment.

Byrncut prides itself on being a highly efficient and safe miner, ensuring the maximum productivities are achieved with each individual piece of machinery and its staff without compromising first world mine safety standards. In the international contracting market, Byrncut offers a select group of highly experienced mining expatriates to manage the contract and train the national workforce utilising its well-developed systems, processes and procedures.

This is exactly what Byrncut were tasked with and have successfully achieved at Bulyanhulu while overcoming many challenges. The obstacles that are apparent when starting up an international contract at any existing underground operation are common anywhere around the world; tolerated

Total Development Metres per Month

Significant step up in development metres through improved productivities

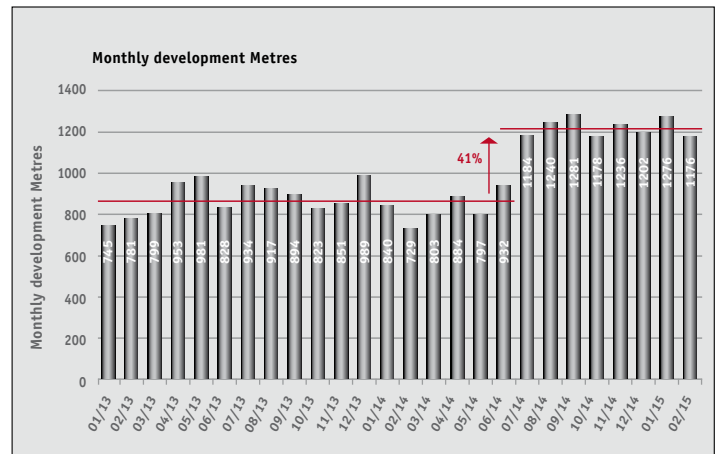

inefficiencies, undesirable safety practises and wasted resources. At Bulyanhulu, Byrncut has successfully taken on the operation and maintenance of Acacia’s development mining equipment fleet, uplifted the safety and skill level of the Tanzanian development workforce and significantly improved the working conditions, quality of work and total development advance.

In March 2015, Acacia published data on their website in a presentation for an Analysts Site Tour that total development metres at the mine had increased by 41% to the previously achieved total development through improved productivities with comparable equipment and personnel numbers. Today that increase in total development metres per month is 63%.

In an updated graph of the same data, the measurement of these step changes is as follows: beginning with the owner mining total advance at 860 metres per month up to 1,232 metres per month for 12 months with Byrncut, with further improvement for the last 9 months to 1,401 metres per month.

This achievement continues to impress with the second graph showing the twin boom jumbo improvement from 64 metres per month each when being operated as an owner miner, through a transition period of achieving 188 metres per month, up to 218 metres per month each. This productivity improvement is more than a threefold increase while contracting the development to Byrncut. These figures have been achieved with the existence of large inherent site delays that are still to be rectified.

Jayde Webb

# Implementation of automated drilling for high speed development

**ByrneCut Australia uses the latest drill technology from Sandvik Mining for its high-speed mine development operations.**

The Sandvik 422i drill with its iSURE software is designed for fully automated development drilling. Robust planning and advanced preventative maintenance keeps the drill operating while the mine is evacuated for mine firing, resulting in additional development advance.

ByrneCut Australia is using the DD422i jumbo with automatic face drilling, optimised boom control and full analysis & reporting functions. The drill plans are designed using iSURE software and uploaded to the jumbo for the machine operator to select and begin drilling using the on-board computer system. Full automatic or semi-automatic modes are available.

Drilling performance can be reviewed using the iSURE reporting module, which collects data on:

- Hole positions and angles
- Boom sequences
- Drilled metres
- Percussion hours
- Penetration rates
- Drilling time per boom
- Automatic boom movement time
- Manual boom movement time

Drill hole data are visualised as a colour coded 3D image and the user can highlight the drilling conditions as a colour 3D map with changes in rock conditions as the development advances. This helps optimise the drill parameters, extends tool life and provides data for assessing the rock support and blasting designs.

The 422i jumbo has 18ft fixed feed rails and uses 5.5m long drill steels for a maximum hole depth of 5.2m and an average pull of 4.9m.

Precise boom control gives good hole accuracy, reduced excavation tolerances and minimal overbreak. Computer control means a consistent blast hole depth and a clean

blasting face, which greatly assists bogging and clean-up. The time needed to scale the headings prior to installing ground support has decreased by 50%.

## ■ Practices

ByrneCut Australia introduced the DD422i at the Jundee Gold Mine in order to achieve over 1000m of lateral advance with one dedicated bolting jumbo and a second machine in front on ground support duty.

The supports are galvanised 2.4m long friction bolts with welded mesh. The Sandvik DD421 jumbos are fitted with 10ft rails to enable split sets to be installed in headings from 4.5mH to 6.0mH.

The development cycle consist of boring blast holes, charging and firing, re-entry, bogging and support setting. The headings are fired at the end of the shift. Travel time, handover and fume clearance means a jumbo operator works 10 hrs in each 12 hr shift. ByrneCut Australia is using the DD422i automatic function to maintain face drilling while the drill is un-manned, resulting in additional lateral advance.

Sandvik DD422i Drilling Jumbo





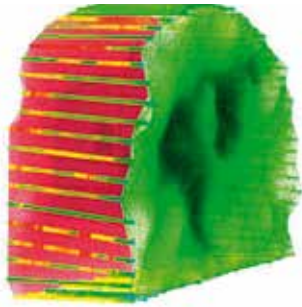

Coloured 3D map illustrating the changes in rock conditions



Engineer preparing drill plan using iSURE software

The DD422i is now averaging an extra 20 holes with automatic drilling being used about 50% of the time. The jumbo is moved away from the decline face at the end of the shift to minimise the potential risk of flood damage. The directional changes in the 4.5mW x 4.5mH ore drives present a real challenge for programming the drilling sequence. Only one boom is used for auto drilling in these circumstances. Preventative maintenance is an important element and better machine design and a revised maintenance strategy have extended servicing schedules and added over a shift a month to jumbo utilisation, or some 16m of extra development.

month and ongoing improvements to mine scheduling can only increase utilisation of the auto drilling function to the benefit of Byrnescut Australia and our clients.

*Travis Hawkins*

### ■ Summary

The DD422i's auto drill technology combined with Byrnescut Australia's expertise have helped increase productivity at Jundee. This means an extra 40m of lateral advance per

DD422i auto drill in operation



DD422i auto drilling



Operator console

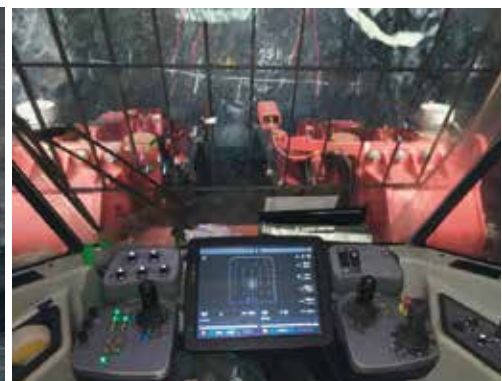



Surface infrastructure at SKS-1 shaft

Aerial view of WS-10 and SKS-1 shaft sites

## Twice a 2,000 meter shaft for Norilsk Nickel – presently the world’s deepest open shafts under construction

Shaft sinking operations to access deeper-lying mineral deposits will always present a huge challenge for project planners and contractors alike. The two WS-10 and SKS-1 shafts form part of the Skalisty mining complex where ore is extracted from the rich deposits of Verchnaya and Glubokaya. Skalisty is

attached to the Komsomolski mine, which is owned by the OJSC MMC Norilsk Nickel group. When the mine construction work has been completed the Polar Division of Norilsk Nickel will be operating the two deepest mine shafts on the Eurasian continent.

Shotcrete support for the shaft walls



### ■ General description of the WS-10 and SKS-1 projects

The two shafts are currently in the sinking phase. Both mines and the initial complex of roadways are scheduled to start operating in 2019.

The two projects are not only on the same scale but also have similar operating parameters and present the same kind of challenges. A similar approach and similar technology is therefore being employed for both operations.





Look into the shaft with its sinking kibble

The shafts are 2,056.5 m deep from surface to sump and have a finished diameter of 9.0 m. The WS-10 ventilation shaft will serve as the upcast shaft and will also be used to convey debris from the roadheading operations (240,000 t/year) and to transport large items of plant and machinery. The shaft will additionally act as an emergency escape route for underground personnel. In order to perform these roles WS-10 shaft is to be equipped with two winding installations, consisting of one skip plant for automatic dirt transport and a cage winding system for emergency deployment and for material conveying. Cast-iron tubbing supports are installed in the upper section of the shaft to a depth of about 138 m,

Guide fittings and tubbing supports in WS-10 shaft



which is in the permafrost zone. The rest of the shaft column is lined with concrete.

Production shaft SKS-1 is equipped with a skip and cage winding system. According to the technical specifications the skip plant has to provide a guaranteed delivery of 1,500,000 tonnes a year.

As with the WS-10 project, the SKS-1 shaft operations include the construction of surface infrastructure on the future mine site, this to be done while sinking is under way, and the sinking and lining of the 2056.5 m-deep shaft, along with the connecting entries below ground (including the shaft insets) and the installation of winding/transport equipment and supply lines in the shaft. For the mine production phase the shaft project also includes an underground ore loading station and an ore discharge system incorporated into the headframe.

Both shafts were sunk by conventional drilling and blasting in conjunction with a six-arm shaft boring machine capable of advance rates of up to 5 m per cycle.

In SKS-1 shaft the sinking dirt was transported out by means of a twin-compartment winder from Olfen-based subsidiary OLKO-Maschinentechnik operating on the 'three kibble system'. The kibles (payload capacity of 5 m<sup>3</sup> and 7 m<sup>3</sup>) were loaded by

a pneumatically powered cactus grab of 0.8 m<sup>3</sup> and 1.2 m<sup>3</sup> capacity. The loading equipment was also supplied by OLKO.

A strata reinforcement system, comprising rockbolts, lagging mesh and shotcrete, was applied from the bottom of the foreshaft onwards, according to the geological conditions encountered. This was supplemented by an inner support system of steel fibre reinforced concrete. The sinking plan provided for the permanent shaft lining of steel fibre concrete to be installed from the mobile shaft stage, independently of the work under way on the sinking floor. This synchronisation of the sinking cycles helped reduce the downtime associated with the need to maintain and repair the concreting system and shaft sinking equipment.

### ■ 7-deck shaft sinking platform on duty

At roughly the same time as the sinking work was under way the shafts were fitted with their permanent guide fittings so that when the shaft bottom point was reached the shaft installation could be commissioned almost immediately. A highly mechanised, 7-deck shaft sinking platform was employed in both sinkings. The special feature of this system is that the platform decks are not suspended from ropes but are supported on the 4.5 m-high concrete blocks that make up the shaft lining. This self-supporting system is therefore able to 'walk' its way down the shaft.

### ■ Key events in 2016

The year 2016 was marked by a number of noteworthy events during the construction of the two shafts. This included WS-10 shaft passing the 1,500 m mark and SKS-1 shaft recording a depth of 1,000 m in the surveyor's log.

By July 2016 WS-10 ventilation shaft had reached a depth of 1,730 m, making it the deepest mine shaft under construction anywhere in the world. At the same time SKS-1 reached a depth of 1,330 m.

### ■ New performance requirements by increasing depth

The sinking record, which placed extreme stress on all parts of the structure and on the operating equipment, not only brought jubilation at the exceptional nature of what had been achieved – which was due in large measure to the endeavours of everyone at the Norilsk Division of THYSSEN SCHACHTBAU – but also introduced a new challenge in the form of increasing wear on the main pipelines and supply equipment when the sinking reached a depth of 1,000 m, this becoming even more evident below 1,400 m.

This problem was solved by using wear-resistant, bi-metallic pipes with special cast-iron inserts at the pipe ends. While these pipes were admittedly more expensive to procure, they did prove to be far more durable than the standard items.

Another challenge presented itself when working through the argillite formations, a zone that exhibited a substantial loss of strength and a high rate of swelling in reaction with water. In order to prevent this it was necessary to block any water entering the shaft floor from the overlying horizons. The solution was to apply a watertight coating immediately to the newly exposed shaft walls as part of the sinking operation.

Concrete supports in the pump chamber





As the shaft operating life was put at some fifty years, any contact with the surrounding strata, even with minimal quantities of water present, would have serious consequences after several decades. All the synthetic coating systems that were tested to this end proved unsuitable due to poor adhesion properties and lack of fire security. Eventually THYSSEN SCHACHTBAU personnel in Norilsk found and implemented a solution that was remarkable for its simplicity and effectiveness.

After some extensive testing the perfect formula was developed for a shotcrete mix with a synthetic additive whose water impermeability offered adequate long-term protection from the water-sensitive rock.

### ■ Fifth anniversary

As well as the significant sinking depths achieved, 2016 also marked another important event – the five-year anniversary of the signing of the contract for the planning and construction of SKS-1 shaft. The date of the agreement on the SKS-1 shaft is an important one for the staff at our Norilsk-based company because the signing of the new contract for the second shaft and the associated surface facilities marked the real development of the Norilsk branch as a structural department in its own right. Looking back over the last five years it is clear that much has been achieved. The increase in the workforce from 200 to 700, the massive expansion of the plant pool with more than 60 vehicles and machines of all types now available in-house

and the erection of more than 30 industrial buildings and installations as part of the WS-10 and SKS-1 mining developments – this says it all.

In addition to the contracts to construct the shafts and build the WS-10 and SKS-1 installations our company was appointed by Norilsk Nickel as the contractor for a number of other projects. These include the drilling of high-tech deep-level boreholes, water sealing measures in mine shafts and the construction of industrial facilities and energy supply systems.

### ■ Important equipment

THYSSEN SCHACHTBAU has the right equipment, the technical expertise and most importantly the skilled personnel needed to tackle difficult tasks of this kind. This is the company's key asset, a kind of gold fund reserve, comprising site managers, engineers, shaft sinkers, electricians and fitters, machine operators, assembly teams and construction workers. And I would like to take this opportunity to thank all of you who have contributed so much to our success in recent years and to wish you good health, good spirits and lots of enthusiasm, and of course continued success in everything you do up there in the Arctic.

### ■ General information on current projects

By the time the WS-10 ventilation shaft had reached a depth of 1,730 m the main 110-kW electricity substation had

Shaft surface buildings



already been built and put into operation. The main ventilation system is also under construction and is currently in test mode. The main mine fans will be set up for real operating conditions following the commissioning of the ventilation system at Skalisty mine in the Verchnaya deposits. The remaining work to be carried out above ground includes the construction of the belt conveyor drift and the conversion of the headframe and winder house for regular mining operations.

### ■ Drivage record

Work undertaken in and around WS-10 shaft in 2015 also included the excavation of shaft insets at the 1173.5, 1263.5 and 1282.5 m levels. This involved the placement of 3,618 and 2,351 cubic metres of support concrete. The shaft-inset drivages, which were completed during the sinking phase, also set a new record. Just 28 days were required to create a single-entry inset with two branch-offs, a total excavated volume of 1,253 m<sup>3</sup>, including the concrete support lining and the concreting of the inset floor.

By the end of 2016 SKS-1 shaft had reached a depth of 1,380 m, an operation that also included the excavation of the inset on the 1,320 m level.

By the end of 2016 the building housing the mine air-conditioning system had been completed and all the associated equipment was installed. This also included full commissioning and a test run.



Installing the concrete formwork in the inset area

Foundations are currently being prepared to support the buildings for the cage and skip winding systems. According to the construction timetable these installations are to be delivered and assembled at the beginning of 2018. All the structural and electrical fitting work on the buildings must therefore be completed in good time so that the winding machinery can be installed within the specified timeframe.

Main electrical substation



Mine air-conditioning plant





### ■ Visit of the Head of the Russian Orthodox Church

The year 2015 also brought some surprises. The most significant non-operational event of 2015 was the visit by the Head of the Russian Orthodox Church, Patriarch Kirill, to the WS-10 construction site. This took place in conjunction with his tour of the Norilsk Episcopate. We are extremely grateful to our client, Norilsk Nickel, for having placed such trust in us and for the appreciation they have shown by arranging for such a high-ranking figure to be welcomed as a guest at our site.

### ■ Water inrush into the shaft – countermeasures

For us, the most unexpected event of 2015 took place at a depth of 1,225 m in WS-10 shaft, which suffered an inrush of water at a rate of some 18 m<sup>3</sup>/hour. Considering that the results of shaft preliminary borehole KS-55 found no water inflows between the 400 m and 1,650 m levels, and the hydrogeological circumstances prevailing in the adjacent shafts showed no indications whatsoever of water ingress at this depth, this incident was seen by a number of experts as marking a new chapter in the hydrogeology of the Talnakh deposits.

While the project planning team had provided ample shaft drainage measures, water inflow rates on this scale were completely unexpected, as outlined above. After the groundwater horizon had been worked through and sealed with concrete lining the water ingress problem was very much

reduced. Further injection work, combined with water discharge and drainage measures, subsequently kept water inflow to a minimum.

### ■ New technologies and offbeating solutions

The year 2015 also recorded a number of operating procedures involving new technologies and unconventional solutions. One such application-based operation was undertaken by the electrical team who were required to lay an armoured power supply cable (type YHKGXSfoyn 3x70+3x35/3x+3x2.5ST 6 kW) over a distance of 1,500 m in the WS-10 shaft in order to supply electrical power to the mine workings at a depth of 1,173 m.

To this end the project department engineers, operating under the proviso of maximum work safety, designed and developed a cage assembly that would facilitate the transport and positioning of the cable in the shaft. This structure featured a braking mechanism that was designed to suppress the rotation of the cable drum and prevent any automatic reeling of the cable when the cage was stopped. A mechanism was also provided to ensure that the cable was properly released from the drum.

It took fewer than 3 shifts to fit the 1,500 m cable in the shaft. The procedure was carried out using the safest and most reliable technology. The shorter installation time, which in turn resulted in fewer interruptions to the drivage and excavation work, made for a significant reduction in the cost of the operation.

Patriarch Kirill, Head of the Russian Orthodox Church, during his visit to the site



Shaft wall with shotcrete support



## Summary

Although the current projects are being carried out successfully it is not possible to disregard the global economic crisis and its effect on the mining industry, and particularly the resources sector. This situation will inevitably have a massive impact on our activities.

Against this background THYSSEN SCHACHTBAU is grateful that the client, OJSC MMC Norilsk Nickel, has given us the opportunity to continue our operations under the same financing arrangements and without any reduction in the pace of the work. Executing such a large project calls for close cooperation with and the full support of the client, and this is exactly the situation that applies at THYSSEN SCHACHTBAU's Norilsk Nickel project.

As well as working on the main projects at the WS-10 and SKS-1 sites we were able to considerably expand our activities in the wider industrial area around the city of Norilsk. This included acquiring a foothold in the exploration drilling and development market and completing two high-tech boreholes for Oktyabrsky mine. These 535 m-deep holes have an external casing diameter of 325 mm and are to be used as supply lines for stowing concrete. Two projects are already under way this year to drill four underground boreholes each of 211 m at Zapolyarny mine. These will serve to supply electrical power from a distribution station.

THYSSEN SCHACHTBAU also successfully executed a project aimed at providing effective water sealing measures in the WSS shaft at Oktyabrsky mine, where inflow rates had reached as much as 300 m<sup>3</sup>/hour.



RB50 rotary drilling rig for high-tech deep drilling work

Another assignment currently under way involves shared-use main transformer station GPP-52 (110/6 kV) now under construction. This installation, which consists of four transformers each supplying 40 kVA, will eventually supply power to various consumer points at the Norilsk processing plant as well as to the Zapolyarny mine. The new transformer station is being built as a replacement for the GPP-5 and GPP-2bis substations, which are being decommissioned.

Thanks to all these fast-paced developments the THYSSEN SCHACHTBAU team is not losing heart, even in these crisis times, and is looking optimistically to a future where new perspectives and opportunities will always present themselves. And we very much look forward to further involvement in all kinds of mining, structural engineering and mine infrastructure projects on behalf of the Norilsk Nickel group.

*Andreas Neff  
Wilhelm Borgens  
Dr. Oleg Kaledin*

Surface operations in a harsh environment





# ‘By reefer container through the eternal ice.’

**‘We don’t do ,can’t do’...’. This is the maxim that has underlined many of the transport challenges that the Logistics Department of THYSSEN SCHACHTBAU HOLDING GMBH has had to face in recent years. And it has never been more tested than at the present time when economic sanctions against Russia have posed all manner of problems for shipments out to the construction sites of THYSSEN SCHACHTBAU GMBH (TS).**

In 2016 alone more than one hundred applications for goods and services to Russia had to be submitted to the Federal Office for Economic Affairs and Export Control (BAFA), though all were ultimately approved.

And in that same year the Logistics Department was responsible for shipping some 4,100 tonnes of materials and equipment to and within Russia.

View at the port of Dudinka



These transports were assigned as follows:

Destination	weight [t]
Norilsk Region	1,964
Perm Region	1,103
Volgograd Region	329
Internal Russian transports	710

Deliveries to the major construction site at Norilsk, which had to be completed within those few months when the weather permitted access to the area, were shipped out by land and sea in some 111 containers (mainly 40ft in size).

For destinations outside Siberia the Department had to organise 240 truck transports, which is the equivalent of about one shipment per working day. This represented a total of more than 1,000 packaged units, some consisting of up to 20 items or featuring individual weights of up to 17 tonnes. One such load comprised a new trolley for the portal crane that is to be installed at the SKRU2 site. In 2016 more than 5,000 individual items had to be agreed with the different customs brokers in Russia, according to the destinations being supplied.

One particular highlight was the Norilsk-bound shipment of some 320 tonnes of cold-sensitive material from Canadian sister company Sovereign, which was required for sealing work in a disused shaft. This challenging operation involved transporting the material, which was not to be exposed to temperatures of less than 5 degrees Celsius, undamaged from Rotterdam via the Arctic Ocean to the Norilsk construction site during the winter months, with stopovers in Murmansk and Dudinka. The idea was to transport the material in insulated and refrigerated containers (or ,reefers’) originally intended to keep goods chilled. The containers in question were summarily converted and heaters were fitted to ensure that the temperatures inside always reached the upper minimum value. The work of installing the heating units inside the containers was carried out by the TS electro-technical department and was designed to provide additional backup for maintaining the temperature level.

Our longstanding transport partner Taymyr Forwarding B.V. was on hand to ensure an uninterrupted supply of power during the entire route from Rotterdam to Norilsk. Each individual reefer container was also supplied with electricity during the seaborne leg of the journey, even during trans-

shipment in Murmansk, where at that time of the year temperatures fall to minus 15 degrees Celsius.

Uninterrupted container heating was also provided on the final overland stage from Dudinka to Norilsk. On arriving in Norilsk the containers were then stored in a specially prepared hangar at an appropriate temperature level of well above 5 degrees Celsius.

From Rotterdam onwards the temperature variations inside the containers were continuously displayed throughout the entire journey by specially procured sensors, with three of these being installed in each container. Thanks to these measures not one of the containers ever recorded an internal temperature of less than 5 degrees Celsius, the crucial threshold for this valuable cargo. In summing up it can be said that the entire operation, which was a fairly unusual assignment for the Logistics Department, went without a hitch.

The prospects for 2017 suggest a high and continuous flow of transports to Russia. Goods totalling some 1,200 t in weight have already been earmarked for the various projects under way in Norilsk, including steelwork for shaft frames, GPP-52 assembly systems and electro stations, roadheading equipment, drill rig accessories and so on. The company is also planning for heavy loads with unit weights of over 50 t per truck to be transported out to the SKRU-2 construction site during the first half of the year, this comprising deliveries of hoists and winding machines from manufacturers OLKO-Maschinentechnik.

*Christiane Bajohr  
Andreas Masthoff*



Intermediate storage in Murmansk

Arrival at the storage facilities in Norilsk







The SKRU-2 shaft site. State of work July 2016 (7 months after procurement). In the background can be seen the salt spoil tip for SKRU-2 mine, the town of Solikamsk and the river Kama. Copyright Uralkali

## Sinking two freeze shafts for Uralkali

In November 2015 Uralkali AG and THYSSEN SCHACHTBAU GMBH (TS) signed a contract to design and sink two shafts for the new SKRU-2 mine at Solikamsk in the Perm region.

The Polovodovski planning team at the ZEHE JACOBI old inn in Oberhausen



The Russian mining company Uralkali was founded in 1927 and since then has been extracting potash salt from the Verkhnekamsky deposits in the foothills of the Ural mountains. Uralkali has a total workforce of some 20,000 and an annual turnover of around 3.6 bn dollars (2015), making it one of Russia's largest mining companies. From its head office at Beresniki in the Perm district the company operates five mines, which are working at depths of between 350 and 500 m, six potash processing plants and a carnallite processing works. It also has mining licences to work three more areas in the Verkhnekamsky deposits. The five mines currently in operation are served by more than 20 surface shafts.<sup>[1]</sup>

The 2011 merger with Sylvinit AG has given Uralkali access to economically recoverable potash-salt reserves of some 7.4 bnt (measured + indicated) and has boosted annual production to 11.4 mill. t KCl (2015). This had promoted Uralkali into number one spot as the world's largest producer, ahead of Belaruskali (10.3 mill. t)<sup>[2]</sup> and Potash Corp (9.1 mill. t)<sup>[3]</sup>.

Dimensional diagrams showing the two freeze shafts

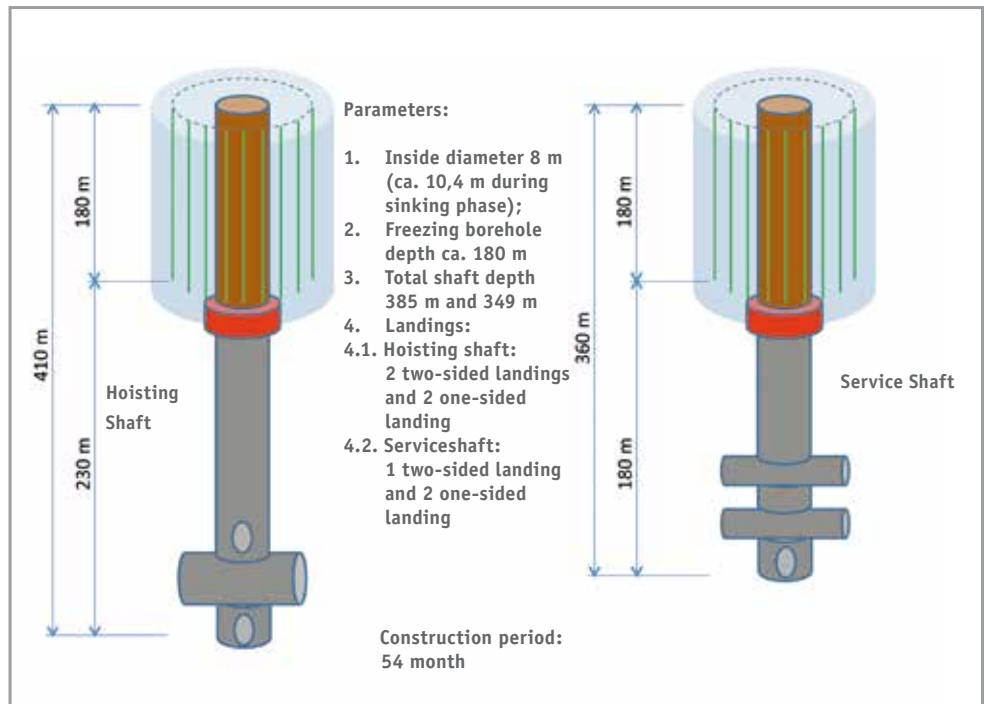

In 2011 the company announced an extensive programme of investment. The construction of new mines at Ust-Yayva, Polovodovski and SKRU-3 (number 4 shaft) will almost double production capacity from 10.6 to 19 mill. t KCl by 2021 [1].

A surface collapse at the SKRU-2 mine in 2014 threatened to put a halt to the entire production process. As a result Uralkali decided that two new shafts should be built at short notice in the southern district of the SKRU-2 facility. Following a curtailed tendering process the sinking contract was awarded to TS. The client was impressed that TS had not only come up with the best technical design but was also prepared to show flexibility in the arranging of the contract, something that this major Russian client particularly appreciated in a period of macro-economic tension between East and West. This was the second major contract that Uralkali had awarded to TS.

### ■ Shaft centre-point boreholes

TS drilled the shaft centre-point holes for the project before being awarded the contract. The resulting drill cores were then examined by the Galurgiya Mining and Research Institute in Perm and the benchmark data for the shaft sinking and underground extraction project were then established on the basis of these laboratory investigations. TS had already worked successfully in collaboration with this practice-oriented institute, which for decades has been using geotechnical and geological data to develop plans for Uralkali mining operations. TS recently concluded a planning assignment for the Polovodovski shaft project and this

received the highest praise from GlavGosExpertisa, the Russian State Inspection Authority for Technical Project Planning. Galurgiya was also involved in the Polovodovski project, providing planning support for the drilling work and analysing the core investigations. The successful conclusion of the Polovodovski planning project was celebrated in style with members of the Russian project team to visit the SCHALKE 04 football supporters' club.

## Remit and operating parameters for the SKRU-2 shaft sinking project

### ■ Project planning

In view of the tight deadlines that were set by Uralkali for the completion of the project TS took the decision to start preliminary planning operations even while the contract negotiations were under way. This involved drawing up specifications for the surface facilities, which included preparatory work on the shaft sites and general infrastructure, and establishing the basic technical data for the two shafts.

### ■ Execution of the work

The decision to make an early start on the planning work meant that operations were then able to commence at the future mine site immediately after the contract had been signed. Access roads were built to the shaft site, a terracing





Start of building: Producing the shaft collar 13,5 m below ground level

process was used to level off and fill the terrain and drilling sites were made ready for the freeze-hole operations. By November 2016, only one year after the signing of the contract, the freeze holes for the first shaft had already been completed. The other works and activities at the shaft site are now so far advanced that sinking operations are expected to begin in early 2017. To reach such a stage a mere 14 months after procurement is indeed a remarkable achievement for a freeze shaft project.

### ■ Technical highlights:

- 1) The use of tried and tested foreshaft sinking technology, which has a Mines Inspectorate approved depth of 150 m, helped to reduce the standby time for the

Bringing the rebar and putting the round formwork for producing the shaft collar



commissioning of the sinking equipment and/or even more usefully provided an opportunity for actual sinking work to be performed.

- 2) The assignment required the shafts to be sunk using the permanent headgear system. The two frame structures had a total weight of some 700 t of welded steelwork. Delivering these shaft headframes at the right time therefore proved a real logistical challenge for the overall project.
- 3) Deploying two sinking stages in the shaft – a 5-deck main sinking platform and a 2-deck tamponage scaffold – is now state-of-the-art sinking technology that facilitates mechanisation and synchronisation of the working cycles in the shaft.
- 4) The use of high-precision freeze boring technology and modern ground freeze processes ensures that both shafts can be sunk safely and efficiently in the water-bearing ground near the Kama river.

The engineering team expects to complete the project and hand over both shafts to Uralkali in early 2020.

*Bastian Winter  
Stanislav Hofmann  
Tim van Heyden  
Eduard Dorn*

### Reference

1. Uralkali. [Online] 2016. [reference dated: 22. 11 2016.] <http://www.uralkali.com/>.
2. Mosaic. [Online] Mosaic Company, 2016. [reference dated: 22. 11 2016.] [www.mosaic-co.com](http://www.mosaic-co.com).
3. Andrews, Vincent and Kumar, Neel. Global Chemicals. s.l. : Morgan Stanley, 2016.
4. PotashCorp. [Online] Potash Corporation, 2016. [reference dated: 22. 11 2016.] [www.potashcorp.com](http://www.potashcorp.com).
5. Belaruskali. [Online] 2016. [reference dated: 22. 11 2016.] <http://kali.by/en/>.

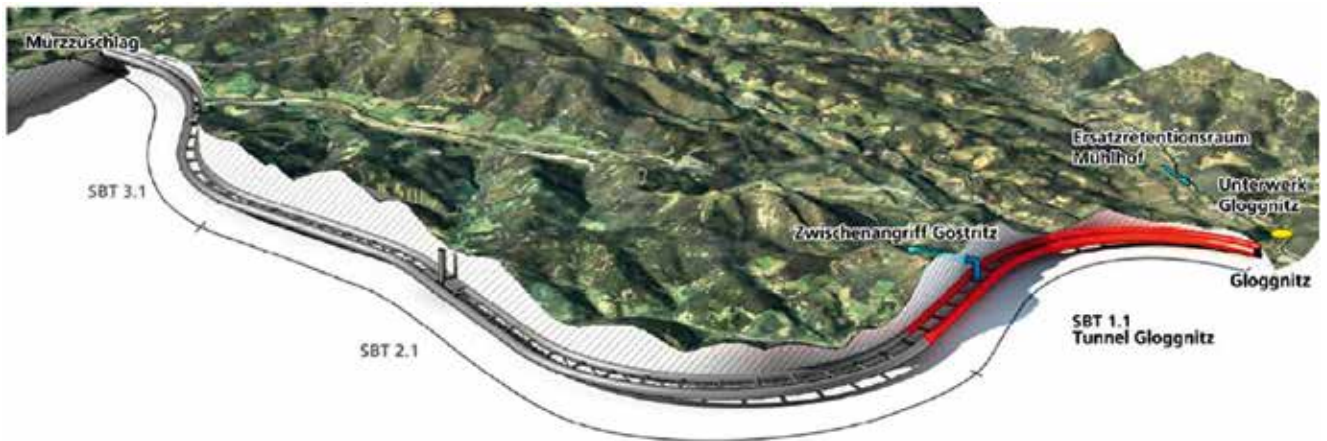
Diagram of contract section 1.1 of the Semmering Base Tunnels <sup>[1]</sup>

# Austria welcomes a new major project at the Semmering Base Tunnel

The new north-south axis being developed along the Baltic-Adriatic corridor from the Czech Republic to Austria, which passes through Vienna and Graz and ends in Italy, will eventually create a new link between the northern and southern regions of the European Community.

Austria's contribution to this operation, which is currently one of Europe's most important infrastructure projects, amounts to some 11 billion euros, the sum that the client ÖBB-Infrastruktur AG (the Austrian Federal Railways) has invested in extending the railway network. The key projects for the Austrian south section are the Koralm rail link from

A hybrid approach is used for the tunnel face and floor excavation



Graz to Klagenfurt and the Semmering Base Tunnel. The latter will help relieve the old Semmering mountainous route, now a UNESCO World Heritage Site, which has long constituted a transport bottleneck, especially for rail-borne goods traffic.

## ■ Semmering Base Tunnel – a major infrastructure project in Austria

The 27.3 km-long, twin-tube railway tunnel starts at Gloggnitz in Lower Austria and passes beneath the Semmering massif to Murzzuschlag in Styria. The Semmering Base Tunnel is split from north to south into three construction sections (Gloggnitz, Fröschnitzgraben and Grautschenhof) with three intermediate tunnels. Work on the central section, designated SBT2.1 Fröschnitzgraben, began in the summer of 2014, while the Gloggnitz tunnel, section SBT1.1, did not officially start until July of the following year. The contract to build the most northerly section, namely SBT1.1, was awarded jointly to THYSSEN SCHACHTBAU and partners HOCHTIEF Infrastructure Austria and IMPLANIA Austria. The total contract value is in the region of 457 million euros, with TS having a 20% share of this, equivalent to some 91 million euros.

The Gloggnitz tunnel section (SBT 1.1) includes the following structural works:

- Gloggnitz portal tunnel
  - two cyclic excavations about 4.6 km in length
  - strata consolidation based on a programme of drilling and injection



Gloggnitz construction site



- Göstritz intermediate tunnel
  - earthworks and specialist civil engineering
  - access tunnel about 1.0 km in length
  - shaft head chamber and base chamber
  - two temporary shafts of about 250 m
  - four cyclic tunnel drivages (2 x 1.5 km and 2 x 1.2 km)
  - strata consolidation based on drilling and injection.

### ■ Gloggnitz portal tunnel

In early September 2015 the cyclic drivages for the two pipes of rail-track 1 and 2 set off from their base-point at Gloggnitz. The excavation work is being carried out either by drilling and blasting or by rotary drum cutter (hybrid

drivage), depending on the strength of the rock being encountered. In the early stages of the operation dumper trucks were used to load out the excavated material. This operation was switched over to a mucking machine in the summer of 2016, with a conveyor belt and crusher system being installed in track number 1.

As the tunnel drivage progressed work also began on setting up the site equipment and facilities. These mainly comprised:

- site offices (own as well as ÖBB) and two workforce accommodation units
- concrete mixing plant and materials laboratory
- workshops and containerised units for the tunnelling crews

Earthworks and specialist civil engineering work for the Göstritz pre-cut



- security centre
- explosives store
- rail siding for loading the excavation material complete with muck boxes and
- water pollution control system.

### ■ Göstritz intermediate tunnel

Extensive earthworks and specialist civil engineering works were needed before the tunnelling operation could commence at the Göstritz site. In order to prepare the construction site work continued through the summer to clear more than 200,000 m<sup>3</sup> of soil and rock, this operation being followed by the installation of some 4,200 foundation piles, 700 multi-strand anchors, 1,100 injection bolts and nearly 10,000 m<sup>2</sup> of shotcrete, all of which were required to secure and stabilise the preliminary cut.

Starting off from the Göstritz portal, and in parallel with the final phase of the pre-cut works, operations began in early May 2016 on the cyclic excavation of the 1,000 m-long access tunnel that would lead to the shaft head chamber. When all the excavation and support work has been completed in the head chamber area the sinking team will start on the construction of the two vertical shafts Göstritz 1 and Göstritz 2. This operation is likely to commence in the autumn of 2017.

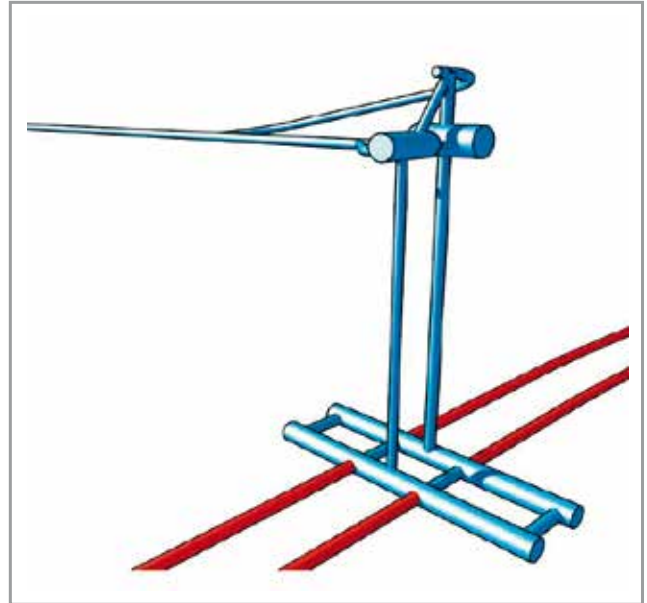

Göstritz intermediate tunnel. [1]

### ■ Göstritz number 1 and number 2 shaft sinkings

The official plans specified that number 1 shaft would be 280 m in depth and 9.0 m in diameter, while Göstritz number 2 shaft was to be 250 m in depth and 7.0 m in diameter.

The two shafts were sunk roughly in parallel with one another using conventional sinking technology. The shotholes were drilled with hand-held jackhammers. The pulls varied in length from 1.0 to 2.2 m, according to the support category. The dirt was loaded into the kibble by hydraulic excavator and then winched up to the shaft head chamber, where it was



Installation of the support system with jumbo





Installation of the support system with jumbo

tipped out and transported by conveyor through the access tunnel to the Göstritz construction site.

As soon as each section of shaft wall was exposed the support system was installed working from the sinking floor, this comprising systematic anchor bolts, weldmesh and wet-sprayed shotcrete. The kibble and conveyor arrangement has proved adequate for transporting consumable materials, tools and equipment to the workplace.

In order to minimise the time needed to change over to the future shaft winding system the machinery that would ultimately be required for the winding installations was planned out as the sinking work progressed.

All the servicing work undertaken in the shaft was carried out either from the kibble or from the working platform. The platform also provided very effective overhead protection for the men working on the shaft floor, allowing for example large items of equipment to be brought in and out, such as the hydraulic excavator that was employed on the sinking floor as a loading machine.

The sinking phase ended when the shafts broke through to the roof of the underlying tunnels. The cyclic crown drivages for the base chamber could then commence, working out from both shafts. The excavated material was also hoisted out by kibble and then transported to the surface via the head chamber and its access tunnel. The tunnelling machines required to develop the base chamber were also brought in and out using a working platform specially built for the purpose.

### ■ Permanent shaft winding system

Shaft winding operations for the main tunnelling phase will commence as soon as work has been completed on the base

chambers and adjoining twin-pipe cavities and the water pumping system has been commissioned.

When regular operations begin the Göstritz 1 and Göstritz 2 shafts will mainly serve as a logistical supply and ventilation pathway and as an escape route in the event of an emergency. Göstritz number 2 shaft will supply the base chamber and four tunnel drivages with fresh air, while Göstritz 1 will serve as an upcast air shaft.

Göstritz number 1 shaft is to be equipped with a single-drum skip winder for transporting the excavation debris from the four tunnel drivages. This installation will have a maximum daily capacity of some 4,500 t.

A large-capacity cage conveyance is also to be installed in Göstritz 1 for main and intermediate manwinding operations and for material conveying duties. The single-deck conveyance will carry a payload of 60 passengers and will be designed to evacuate 120 persons from the bottom tunnel to the top chamber within 30 minutes.

A heavy-duty winding system will be installed in number 2 shaft. Operating in triple-reeved travel mode the heavy-duty cage, which will be fitted with two 25-t electric chain hoists, will be capable of accommodating individual loads (e.g. large items of machinery) weighing up to 40 t. The conveyance could also be used as an intermediate manwinding system with a capacity for 20 passengers.

An auxiliary winding system will also be available to serve both as an escort for the heavy-load transports and as an emergency rescue option for persons located in number 2 shaft.

### ■ Outlook

After some 12 months or so of activity the eventful start-up phase of this major engineering scheme has now been successfully completed by the three partners involved in the SBT1.1 Gloggnitz tunnel project. With the operation having now entered the calmer waters of the three parallel tunnel drivages preparations are now in full swing to tackle the challenges associated with the shaft structures and the drilling and injection work. As a specialist shaft sinking and drilling company THYSSEN SCHACHTBAU GMBH will have a key role to play both here and in other areas of the infrastructure project.

*Thorsten Kratz  
Tamara Portugaller*

#### Reference

[1] Jutta Krainz (22.05.2014).

The new Semmering Base Tunnel  
– underground safety measures.  
ÖBB Infrastruktur.



## Safe and efficient: Shaft sinking at the Brenner Base Tunnel



The Patsch ventilation shaft, which from THYSSEN SCHACHTBAU GMBH's perspective is the centrepiece of the Brenner Base Tunnel (BBT), was completed safely and efficiently in 2014 after just four months work and using conventional sinking methods. The Patsch shaft, which is 182 m deep and has a diameter of 6.4 m, forms part of what is currently one of Austria's largest tunnel construction projects.

### ■ The Brenner Base Tunnel construction project

The Brenner Base Tunnel (BBT) is a horizontal railway tunnel that provides a link between Austria and Italy. It runs 55 km from the Tulfes portal at Innsbruck to the Franzensfeste portal at Brixen in South Tyrol (see Figure 1). Including the existing Innsbruck bypass the BBT measures some 64 km and is the longest underground railway tunnel in the world. The BBT is primarily intended for goods haulage and will therefore help transfer much of the current HGV traffic from road to rail. The project is scheduled for completion in 2025.

In 2014 TS played a major role in one of the main construction sections, namely AP169 – the Ahrental ventilation cavern and the Patsch ventilation shaft.

The Patsch ventilation shaft, which has a finished diameter of 5.8 m and a cross section of 26.4 m<sup>2</sup>, runs vertically from the surface to the Ahrental access tunnel and its ventilation cavern.

Both the shaft and the caverns will be used to supply fresh air over a route stretching from the tunnel areas at Innsbruck

Route of the Brenner Base Tunnel (Source: BBT SE)



to a point about halfway along the tunnel at Wolf am Brenner. This ventilation supply will be needed not just during the construction phase but also throughout the operating life of the rail tunnel. During the tunnel excavation phase the shaft will act as a downcast shaft and after the rail tunnel has been completed it will be switched over to serve as an upcast ventilation shaft.

### ■ Shaft construction

In April 2014 THYSSEN SCHACHTBAU started to prepare and set-up the site equipment in the village of Patsch, south of Innsbruck. After just four days spent assembling the portal crane, which had been specially designed for the assignment, work was able to commence on the shaft sinking.

The sinking crew was divided up into three shifts each of five men. Three or four of the team were engaged in the excavation work on the sinking floor while one or two men remained at the shaft top to operate the winches and organize material deliveries.

The first 20 m of overburden were removed by mechanical excavator and the remaining 162 m were excavated by drilling and blasting.

After blasting each pull, which involved manually drilling up to 70 shotholes, the debris was transferred to the surface using a specially converted short-radius excavator and two dirt buckets each of 4.5 m<sup>3</sup> capacity.

The average sinking advance per day amounted to one fully-supported pull of 1.5 m. The lining support for the inner shaft wall was applied manually and was adapted to meet the local geological conditions and support specifications laid down by the client. The support consisted of two layers of reinforcement mesh, 3 m-long steel rockbolts and two coats of shotcrete up to 30 cm thick.

The excavated section of 6.4 m was maintained to a high degree of precision thanks to two plumb lasers set up at the shaft collar. These lasers were also used to take convergence measurements from a series of measurement horizons each fitted with four measurement bolts. Deformation down the shaft lining was checked on a daily basis in the early days of the sinking, this subsequently being reduced to three times a week.

A cascade-type pump system was originally planned for shaft de-watering. However, due to the increased water inflow at a depth of 123 m it proved necessary to provide an additional drainage well over 60 m in length running down to the shaft



Shaft head including crane facility

bottom level. The well was used to divert the shaft water via the cavern at shaft bottom.

After four months of construction work the shaft broke through into the Ahrental ventilation cavern on 4 September 2014.

When the ventilation shaft had been completed a mesh screen was installed at shaft bottom as an additional safety measure to prevent objects falling into the Ahrental access tunnel. In order to facilitate future maintenance work a shaft inspection platform was set up at the shaft head and a surface shaft house was also erected.

### ■ Occupational health and safety

The construction work was completed accident-free, thanks to the care and attention displayed by TS personnel and the work-safety measures that were adopted. In addition to the normal safety measures in place two emergency exercises were also conducted at different shaft levels in order to prepare for potential incident scenarios and raise everyone's

awareness to existing dangers. These exercises were attended by members of the local fire service, the shaft sinking team and representatives from the client company and developer.

### ■ Conclusion

Every aspect of the work on site was performed to the complete satisfaction of the client and the developer and we therefore wish at this point to extend special thanks to everyone at TS who was involved with the project.

*Tamara Portugaller  
Stefan Schichtel*





System formwork for the construction of the concrete shaft liner

# THYSSEN SCHACHTBAU – delivering a professional service at the esco-owned Borth salt mine

**THYSSEN SCHACHTBAU GMBH has been positioned on site at the Borth rock-salt mine since 1992. During this 24-year history a multitude of work has been carried out for the client esco European salt company GmbH & Co. KG (esco). Clever personnel and deployment planning has enabled the company to work a multi-shift system without interruptions, which has been particularly effective in recent years.**

The fact that the mine’s operating shafts are now showing their age (sinking commenced early in the last century), that they have been constantly subject to geomechanical influences and that during the sinking phase – especially during the First World War – the company responsible had to skimp on material, have proved to be a bonus for us as a shaft construction company. Production output was for many years the main focus of attention at the mine. Borth 1 and Borth 2 shafts as its most important infrastructural elements were generally neglected. The result was a huge backlog of shaft repairs. The mine’s own shaft construction teams are fully occupied with daily maintenance and inspection work and with transport duties and this situation has allowed TS to remain a valuable and reliable provider of services to esco

for many years. Having a permanent shaft-construction station at the mine has enabled TS shaft sinking division not only to deploy experienced personnel there for many years (working on the shaft stages and guide fittings) but also to involve apprentice shaft sinking engineers on an ongoing basis.

## ■ Shaft data

### ■ Borth number 1 shaft

Borth number 1 shaft serves as a production shaft and as an upcast ventilation shaft streaming air volumes up to 13,000 m<sup>3</sup>/min.

The steel buntons are set 3.0 m apart and the shaft insets are located at the 606 m, 718 m, 740 m and 820 m-levels. The main floor level is at 740 m, while the 820 m-level is the old coal supply route.

The following table shows the type of shaft lining installed at the different levels.

From depth [m]	To depth [m]	Type of lining	lining diameter [m]
0.00	3.00	brickwork	6.0
3.00	555.00	1st tubing	6.0
3.30	553.00	2nd tubing	5.0
553.00	848.00	Pre-cast concrete blocks	6.0
710.00	755.00	support rings	5.7

Chart 1

### Borth number 2 shaft

Borth number 2 shaft, which is the downcast fresh air ventilation shaft, draws in up to 10,000 m<sup>3</sup> of air a minute. It is equipped with a main winding system with counterweight and a large-capacity cage with a deck for 22 persons, which travels at a maximum speed of 12 m/s. The cage is used for both manriding and for transporting materials and explosives. The lining in number 2 shaft is of a similar arrangement to those employed in number 1 shaft, apart from small differences in the depth of the sections.

From depth [m]	To depth [m]	Type of lining	lining diameter [m]
0.00	4.30	brickwork	6.0
4.30	561.00	1st tubing	6.0
57.45	517.90	2nd tubing	5.0
561.00	850.00	concrete blocks	6.0
606.00	750.00	support rings	5.7

Chart 2

Down to the -520 m-level the steel buntons are set at intervals of 4.5 m, after which they are spaced 3.0 m apart.

Some of the routine assignments we have undertaken in the shafts over the years include:

- Stabilisation work in Borth number 2 shaft (lining)
- Refurbishment of the guide fittings in Borth number 1 shaft
- Stabilisation Refurbishment of number 1 shaft pit bottom (-718 m)
- Reconstruction of the Skip loading installation for number 1 shaft
- Replacement of timber buntons by steel guide rails in number 2 shaft
- Installation of an API pipe in number 2 shaft

- Replacement of the guide frame in number 2 shaft and installation of the large-capacity cage
- Installation of support rings and backfilling work in both shafts
- Installation of platforms in the shaft sump zone of number 2 shaft and
- Reconstruction of the escape route between the shafts.

### Current status and future projects

#### Tubbing refurbishment

TS is currently meeting its contractual obligations to carry out tubbing renovation work in Borth number 1 and number 2 shafts. This involves the cleaning and sealing of the tubbing segments.

In Borth number 1 shaft the operation involves the removal of some 8,677 m<sup>2</sup> of tubbing between levels -3 m and -553 m. The segments are taken out section by section and cleaned in order to prepare them for re-sealing.

Area of withdrawn gutter, view onto the inner tubbing



Cast-iron tubbing plate after the cleaning







1st concrete block of the support reinforcement shaft 2 after the stripping of the formwork



F.r.t.l.: Ms Dahlmann and Messrs Reifschneider and Plack explaining the project

In number 2 shaft the tubing columns from level -4 m to level -561 m are taken out and cleaned of their rust and caked-on salt and saltpeter. This work entails the removal of about 9,050 m<sup>2</sup> of tubing, which is then to be re-installed and sealed.

TS is currently engaged in cleaning the tubing elements in number 2 shaft. Because of the heavy build-up of incrustations the contract has now been extended into its fifth phase of work. The residue material, which is irregularly distributed over the surface of the elements, has to be completely removed. Once the cleaning work has been completed and the inflow situation is assessed mine operators esco will decide on the need for, and scope of, the subsequent sealing and grouting operation.

### ■ Borth number 1 shaft - installation of support rings (Project 2015 - 2017)

Additional support rings are to be supplied and installed in the concrete-block section of number 1 shaft (see Table 1). The first stage of the operation, which was carried out in 2015, provided for the installation of additional support rings in a 10 m-long section of shaft. According to the plans some

14 type-TH 44 rings were fitted at intervals of 750 mm. The rings were then covered with lagging mats and the annulus backfilled with material.

The TH rings (each ring consisted of six TH 44 bars) were installed from the top downwards, while the backfill was placed working upwards from the bottom. The installation team worked from a telescopic platform that was switched between the east and the west shaft conveyance, as required. The installation was carried out as follows: the first ring (‘ring zero’) was precisely measured and positioned all-round on tub axles set into the side-walls before being anchored into the shaft wall. Subsequent rings below ‘ring zero’ were then attached, installation being undertaken section by section with three segments being fitted from the west platform and a further three from the east before the individual rings were closed. This approach saved time on having to re-set the working platform. When all the ring supports had been installed the annulus was filled with building material. Backfill mats and sealing strips were then inserted into the intervening spaces so as to prevent any escape of building material into the shaft. The mixing pump and material were positioned on the floor of the conveyance

Support ring and 1st concrete block after stripping of the formwork

Top level of the system formwork and overlapping reinforcement

Steel ring support Shaft Borth 1



and the working platform was used for keeping the NaCl brine topped up and for supplying the mixed material to the point of use.

The second stage of the operation, which encompasses a length of 30 m, commenced in the summer of 2016. This successful undertaking by TS will continue in the months and years ahead until the entire shaft column has been secured. The stabilization work that will be required for the next stages of the project will be carried out in a similar manner. Further project work

As well as its existing contracts in connection with Borth number 1 and number 2 shafts TS has for several years been engaged in an ongoing contractor's agreement that has recently been extended for another two years to 2018. This particular contract requires TS to undertake various assignments in the mine shafts. This involves relatively minor tasks that can generally be completed in three to four shifts and which can be called up at short notice depending on the amount of work required.



Reinforcement cages at the side for the construction of the support reinforcement

At the end of 2016 the first shaft liner was installed in number 2 shaft as part of a support reinforcement project that involved pouring reinforced steel concrete with the help of a moving formwork system (operating from pit bank to a depth of about 58 m). This reinforcement system shall provide stable and long-term support for this section of shaft.

Other projects in Borth number 1 shaft include the installation of rockbolts and lagging mats over a wall area of some 500 m<sup>2</sup> in the concrete lining zone.

TS will also be re-aligning the entire system of shaft guides and buntons, while in number 1 shaft the loading station, which has been damaged by strata convergence, needs to be replaced and adapted for use.

Using its geotechnical expertise TS will also be conducting stability surveys on the tubbing columns in both shafts. The on-site personnel will be responsible for the preparatory work, including the cleaning of the measurement points and the taking of wall thickness measurements.

## Conclusion

Overall, the company's order-books appear to be secure for the next few years. The client esco frequently cites the excellent working relationship that has been built up with TS and has acknowledged the high-quality, tidy and reliable work that we have delivered to date. The mutual respect that has developed between us has reinforced our credentials as a dependable partner for specialist mining assignments – and one that the client has come to rely on.

*Arne Plack  
Heinz Reifschneider*

Practice for the fall protection system HS3  
2016, Borth Mine





Gorleben no. 1 shaft

## 30 years of THYSSEN SCHACHTBAU GMBH operations at the DBE exploratory mine – from the sinking of the shafts Gorleben 1 and 2 as far as the repository-standard abandonment of exploration drill holes concludes THYSSEN SCHACHTBAU GMBH deployment at Gorleben

The DBE (German Society for the Construction and Operation of Waste Repositories), acting as a third party in accordance with § 9a, paragraph 3, of the Atomic Energy Act of the Federal Republic of Germany, as represented by the Federal Office for Radiation Protection (BfS) in Salzgitter, has been entrusted with the planning, construction and operation of facilities intended for the final storage of radioactive waste. Since 1979 the DBE has been engaged in a geoscientific exploration programme aimed at investigating the Gorleben salt dome with a view to determining its suitability as a final repository for radioactive waste of all kinds.

### ■ A historically significant project for THYSSEN SCHACHTBAU GMBH (TS)

After an intensive period of surface exploration work, the underground exploration phase commenced with two shafts – Gorleben 1 and Gorleben 2 – which were sunk some 400 m

apart during the periods 1986 to 1997 and 1989 to 1995 respectively. This was followed by the excavation of underground roadways and a programme of underground exploratory drilling. The freeze holes for the two shafts were sealed to provide long-term security to waste-repository standards with a view to the facility being used for the storage of high-level radioactive waste.

Installing high-integrity seals in the exploration holes was the final operation undertaken by TS at Gorleben Mine. This marked the end of an important chapter in the company's history as a shaft sinking and drilling contractor.

### ■ Sinking Gorleben 1 and Gorleben 2 shafts

The freeze sinking technique was used when excavating, supporting and lining the shafts in the unstable, water-bearing section of overburden and cap rock. Based on results obtained from test wells a freeze depth of 268 m was established for shaft no. 1 and 264 m for shaft no. 2.



Automated welding of the steel casing before the construction of the inner lining



Constructing the foundation for the sliding shaft lining

The freeze-holes and temperature measurement holes for both shafts were drilled and fitted out during 1984 and 1985. After the pilot shaft had been completed and the sinking equipment assembled, the sinking work was able to commence under the protection of the solid ice wall. Sinking in Gorleben 1 commenced on 11 September 1986 and in Gorleben 2 on 8 May 1989. Most of the sinking work in the frozen ground was carried out by drilling and blasting; however, a specially developed shaft miner was also employed in certain areas of the cap rock.

### ■ Shaft lining in the cap rock

In the unstable overburden zone, both shafts were fitted with a final composite lining consisting of a steel-concrete cylinder enclosed in a fully-welded, watertight steel plate casing with an internal diameter of 7.5 m.

The inner support system, which is separated from the outer lining by an asphalt joint, was installed working downwards from the top of the shaft. This inner support column was set into the stable salt strata to a depth of some 90 m below the

salt dome. Such a support system ensures complete water tightness and little or no maintenance or repair work will be required over the lifetime of the facility.

### ■ Shaft section in saliferous strata

No stabilisation measures were needed in the saliferous rock until the sinking reached its final level. The sinking work was undertaken using conventional drilling and blasting. Five extensive geotechnical exploration horizons were set up and fitted with instrumentation in both shafts. Shaft no. 1 reached its final depth of 933 m on 10 November 1997. An exploration horizon was started at a depth of 840 m and a conveyor station was constructed at the 880 m-level.

The shaft bottom ramp, which runs from the 840 m-level to the deepest part of the shaft at the 933 m-level, is suitable for large vehicles.

Shaft no. 2 reached its final depth of 840 m on 18 November 1995. Two mine horizons were also developed from the shaft, a return-air level was set out at the 820 m elevation and an exploration horizon at the 840 m-level.

Infrastructure: Roadways at the 840 m-level







Infrastructure: Workshop at the 840 m-level

### ■ Mine infrastructure and exploration zones

The second project phase, which included underground exploration, the excavation of roadways and cavities for the mine infrastructure and reconnaissance zones and some 30,000 metres of horizontal drilling holes, commenced in shaft no. 1 on 4 October 1995 with the construction of the station on the 840 m-level. Similar work started in shaft no. 2 on 18 November of the same year. These break-outs were then used to create a connection between the two shafts via the main drift. The two connecting drifts joined up on 21 October 1996.

The excavation programme also included the construction of mine infrastructure facilities, including workshops, working areas and storage chambers.

Excavation work on the crosscuts '1 west' and '1 east' and the northern lateral road marked the beginning of the development of the Stassfurt salt series in exploration zone 1, which has been designated for the long-term storage of heat-generating nuclear waste.

Infrastructure chambers at the 840 m-level



### ■ Long-term abandonment of the freeze holes and temperature measurement holes to final-repository standard

The long-term security requirements imposed on final repository mines of this kind included the stipulation that all freeze pipes and temperature measurement pipes at both shaft sites should be removed and the holes then filled with a suitable material to act as a long-term seal. Completely filling the freeze holes will permanently prohibit any exchange of mineralised solution taking place between the overburden strata and the salt dome. A total of 44 freeze holes and four temperature measurement holes had to be treated at each shaft site. This operation was successfully completed in March 2009 by personnel from the TS drilling section.

Update on the Gorleben salt-dome exploration programme

There is general international consensus that the use of deep geological deposits for the permanent storage of high-level radioactive waste (HAW) in specially prepared mine workings is technically safe and feasible and constitutes the best available option. Because of its properties, and the existing

body of knowledge in this area, mineral salt is particularly well suited to serve as a host medium for the permanent disposal of higher-activity waste (HAW) material.

The results obtained to date from the first exploration zone confirm the area's potential suitability as a high-level waste repository. Gorleben is the most thoroughly explored potential HAW storage facility in the world. However, a final decision on the suitability of the Gorleben site will only be possible once surveys have been completed in all those parts of the salt dome that are to be used for storage purposes. Underground exploration work did continue in the Gorleben salt dome for a certain period, though was subsequently halted for political reasons with the introduction of the Repository Site Selection Act (StandAG) on 27 July 2013. According to § 29, section 1, of the StandAG the Gorleben salt dome is to be included in the repository site selection procedure in the same way as any other potential active-waste site. The underground exploration area therefore has to be taken out of operation and the mine kept open pending another Federal Government decision. The exploration holes drilled up to this point in time have to be filled and sealed to final-repository standard in accordance with the mine access plans.

### ■ Repository-standard abandonment of the underground exploration boreholes

At the request of the DBE TS deployed a team of up to 16 workers on a temporary staff leasing basis in order to undertake repository-standard filling of the underground exploration boreholes at the Gorleben site. The final deployment period commenced in March 2014 with most of this workforce embedded in the DBE drilling team where TS – while working under the leadership of DBE – provided most of the shift

foremen, drillers and drill-rig operators involved in the quality-assured abandonment of the underground boreholes.

DBE was entrusted with planning and executing the seals required for the deep, large-volume exploration boreholes and shallow, small-volume holes.

The geological exploration and survey holes previously drilled as part of the salt-dome investigations were created using the core drilling process. The equipment used for this operation comprised Diamec drills from Atlas Copco and a drill from Wirth. The holes were drilled at various points throughout the mine workings, though focused primarily on the 840 m-level (the exploration level). The seals were constructed in compliance with the instructions issued by the mining supervisory authorities of Lower Saxony and the State Office for Mining, Energy and Geology in Clausthal-Zellerfeld.

In order to ensure that the best possible seals were obtained, a number of suitable fill materials were examined and/or developed and a quality assurance programme was developed and incorporated into the DBE quality management system. This meant that all the key aspects of the borehole abandonment operation were laid down in the quality assurance programme. The fill material and the individual stages of the operation, from the supply of the material to the injection phase, were all controlled, tested, monitored and documented. The relevant technical specifications, test reports, EC declarations of conformity, safety data sheets, risk assessments and health and safety documents were all developed as required. The operating team members were given appropriate instructions and training.

A number of individual boreholes had to be surveyed, geophysically examined and logged prior to filling. This







Equipment used for sealing the shallow boreholes

operation was carried out using various types of measurement probes, including hole calibre probes and optical probes. This meant that the hole diameter, layer boundaries and other rock parameters were determined digitally.

The requirements to be met by the borehole injection material, including long-term resistance, chemical compatibility with the salt rock and workers' safety, also had to be verified and tested. Various operational trials therefore had to be conducted prior to the actual borehole injection phase. This meant confirming the logistical parameters, technical capabilities and workability of the different material components and formulations, along with the rheology and homogeneity of the injection material. The individual Inspection Test Plans included:

SC-500-K suspension mixer



- Incoming goods inspection
- Cold and secure storage of temperature-sensitive materials
- Transport below ground by shaft conveyance followed by transfer to the hole site
- Deployment and processing of the appropriate quantities of injection material
- Curing behaviour and pumpability of the various materials

In-situ measurements (quasi-adiabatic temperature tests) were carried out on the target materials and additional investigations were undertaken using external laboratories. These included measurements to determine the air void content, suspension density and temperature, slump tests, Marsh funnel viscosity tests and V-funnel flow time tests. This programme of tests also included the preparation and correct storage of retention samples and test specimens.

After verifying and readjusting some of the parameters, where necessary, the operation moved on to the borehole injection stage proper. The mixing and pumping equipment used for this work was supplied by MAT of Immenstadt.

A 250 litre SC-250 K suspension mixer and HP-15 E peristaltic pump were used for filling the shallow, low-volume holes. A digital flowmeter was used to record the quantities of material consumed. For the deeper holes it was necessary to employ a 500 litre SC-500-K suspension mixer, while a forklift was deployed for handling the fill material.

Heavy-duty mixing equipment ultimately had to be brought in for filling the deep, large-volume exploration boreholes. The holes were filled using a large-diameter plastic hose that was fully inserted into the bottom of the borehole. A hose reel was used so that the hose could be continuously withdrawn as the fill material was pumped in.

The SCC 20 1,000 litre suspension mixer was kept supplied by a screw conveyor operating from a Big Bag unloading point.

The entire operation was professionally executed by personnel from DBE and TS. The drilling and injection equipment presented a number of technical challenges and also provided valuable data for future sealing projects of this kind.

## ■ Summary

The conclusion of TS's operations at the Gorleben underground repository marks the end of an important chapter for the

company whose history as a specialist mining contractor goes back nearly 150 years.

This unusual waste repository project with its various technical issues has long been the centre of much political attention. The undertaking has posed a series of challenges for everyone involved, including the contractors, geologists, authorities, institutions and political parties, and has required them to perform at the highest level. In our view the underground repository that has been created is a world-class facility which outstanding construction concepts and building quality, operating technology and resilience, as based on sound geological and geotechnical exploration work, have become the envy of the world. It is therefore all the more regrettable that political constraints and party policy manoeuvres have again brought the project to a halt. The geological exploration of the salt dome should at least have been brought to a proper conclusion so that all the remaining salt dome zones intended as waste storage areas would have been investigated and definitive findings made available as to the suitability of the dome. However, political interests were not prepared to allow this and there was clearly some concern that additional facts and evidence would come to light that would further support the view that



Big Bag unloading station

the salt dome was a suitable site for the final storage of intermediate and high-level radioactive waste.

The mine will now be kept open for some years to come until the Federal Government reaches its decision.

*Hubertus Kahl  
Rolf Krause  
Michael Mizera*

Deep borehole filling with PE hose coil





# Building a bitumen and ballast abutment seal for vertical mine workings in a permanent waste repository in Germany

The project to decommission the Morsleben final repository for radioactive waste (ERAM) provides for the construction of roadway and shaft stoppings and additional seals in the southern ventilation drop-hole. These structures are a key part of the safety measures being put in place for the long-term safety certification of the facility. The various seals are intended to separate the residual mine workings from the waste storage areas and in this way to prevent nuclide transfer.

As the seals in the shafts and in the southern drop-hole will not be constructed using standard engineering methods because of the requirements imposed on the building materials and the background conditions prevailing in at ERAM it was decided that a full-scale trial should be carried out in a staple pit in order to demonstrate the general feasibility of constructing an abutment seal from bitumen and ballast.

Structural design of the full-scale trial

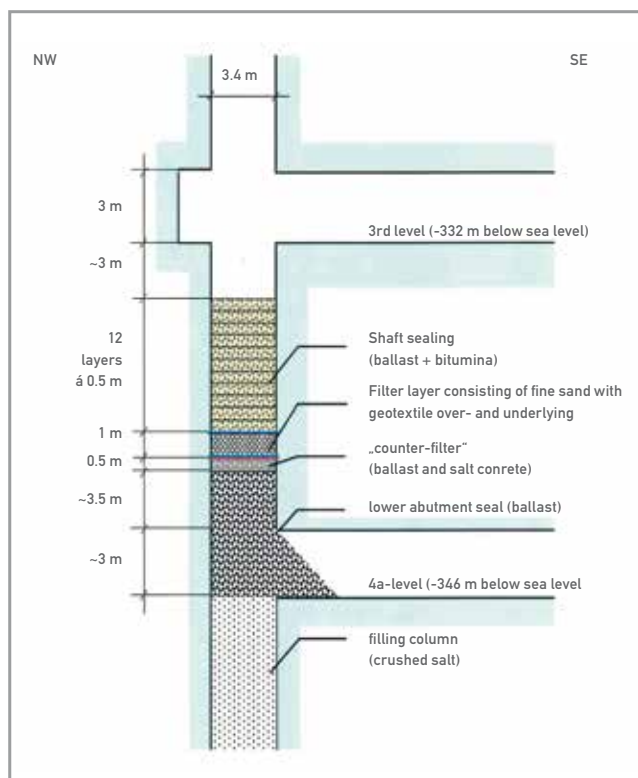

A dedicated measurement program was set up in order to record the temperature and pressure profile within the abutment seal.

The main aim of the underground full-scale trial was to demonstrate the feasibility and effectiveness of the structure, particularly in terms of:

- the logistics associated with the provision and installation of the ballast and bitumen
- the quality assurance measures and
- the health and safety measures in place.

The full-scale trial also sought:

- to record the thermal behaviour of the bitumen-ballast-rocksalt system and
- to confirm the functionality of the sealing element by providing verification of the hydrostatic bitumen pressure.

It was planned to carry out the large-scale trial in the IB drop-hole 1B located between mine level 4a (346 m below sea-level, hereafter referred to as ‚level 4a‘) and mine level 2 (291 m below sea-level, hereafter referred to as ‚level 2‘), with the shaft stopping being installed between level 4a and mine level 3 (332 m below sea-level, hereafter referred to as ‚level 3‘). Between mine level 4 (372 m below sea-level, hereafter referred to as ‚level 4‘) and level 4a the IB drop-hole was to be filled with crushed salt.

The work performed for the trial essentially comprised the following:

- the preparation of all documents relating to the shaft stages, rope installations, material supply equipment and winching systems, as required for preliminary inspection by an acknowledged expert from the State Office for Geology and Mining of Saxony-Anhalt (LAGB), in accordance with § 4, section 3 (2) of the Saxony-Anhalt Mining Ordinance for Shaft and Inclined Haulage Systems (BVOS), together with all (preliminary) test reports
- the drafting of vendor-specific planning documents for all the equipment and installations needed to provide the specified services, this comprising in particular the winding systems and conversion of the drop-hole cover plates, and for the execution of the building work,



Winching systems at the shaft top

including the construction site equipment the provision, transport and assembly of the construction site equipment, together with all the plant and equipment needed to undertake the specified operations

- all safety-related measures for the drop-hole, along with the construction and dismantling of the working stages in this area
- delivery to the site of all the required materials, where these are not provided by the client
- the construction of the complete abutment, sealing element and filter layer, and
- the provision of support for the geotechnical instrumentation.

The DBE (German Service Company for the Construction and Operation of Waste Repositories) commissioned the consortium Abutment Seal to carry out the aforementioned work. The consortium comprised the joint-venture partners TS BAU and THYSSEN SCHACHTBAU.

Given the importance attached to the operational aspects of the project in the planning approval process extreme care had to be taken to ensure that the building work was carried out smoothly and seamlessly. In this connection a high priority was attached to the prevention and avoidance of workplace accidents.

## ■ Project execution

The large-scale underground trial to construct a bitumen and ballast abutment seal was carried out at the Morsleben waste repository (ERAM) from 29.06.2015 to 30.10.2015. The equipment deployed consisted of one small manwinding system and one combined emergency and materials haulage winch.

Shaft cross-section and ventilation tube







Square cross-section of the shaft

On level 2 the existing shaft cover was replaced by a sliding cover plate and a sheave frame was also set up. On level 3 the existing shaft cover was replaced by a new item with two sliding plates. Following the necessary mechanical and electrical approval process IB drophole 1B was divested of all its fittings and fixtures between levels 2 and 4a. Shuttering was then installed on level 4a and a compaction test was carried out with the ballast material. The crushed-stone abutment was then installed in 28 layers and compacted. This operation required a total of 201 big-bags containing more than 202 t of crushed stone. The construction team incorporated salt concrete with a smoothed salt-concrete base slab into the top 10-cm layer of ballast. Sealing foil and

Big-bag unloading station



geotextile were laid out over the counter-filter and then worked into the joint.

A 90 cm-thick Bentofill filter layer was then installed and compacted in four layers. This required the processing of more than 22 t of material. Another geotextile system was laid over the filter layer and let into the shaft joint. The team was then able to set up the measuring instruments at four different horizons. Finally, another sealing element, comprising crushed stone and bitumen, was built up and compacted in 24 layers each 25 cm thick.

After each two successive layers the bitumen was applied in accordance with a predefined casting plan, the only exception being the second pouring layer which was only 25 cm in thickness. The construction of the sealing element required 133 big-bags, containing more than 131 t of crushed stone, and 56 fills of the bitumen boiler, equivalent to more than 35 t of bitumen. After a waiting period of two weeks the bitumen level was checked for signs of sagging and more bitumen was poured in if necessary. Only then was the site equipment dismantled and removed.

### ■ Summary and outlook

No notifiable accidents were recorded throughout the entire construction period. Cooperation between the client, the contractors, the competent authorities and the official experts all went very smoothly and the project was completed on schedule. Now that the large-scale trial has been concluded and evaluated the findings obtained from the accident-free

operation can be used to plan and construct reliable and environmentally compatible seals and stoppings in vertical mine openings at the Morsleben final repository for radioactive waste using a safety concept that is designed to meet long-term certification requirements.

THYSSEN SCHACHTBAU's involvement in the project has provided the company with a unique reference that has been widely recognised in expert circles.

*Tilo Jautze  
Jörg Schwarz*

## Radioactive waste repository Konrad – Status of work in the filling station, the shafts and the North section ASK1 and ASK 2



Roadway section profile with bolted support and concrete covering

As part of the operation to prepare the former Konrad iron mine for the storage of low- and medium-level radioactive waste, which has been ongoing since 2009, THYSSEN SCHACHTBAU GMBH and joint venture partner Deilmann-Haniel GmbH have been awarded a further two contracts by the client DBE (German Service Company for the Construction and Operation of Waste Repositories). Following on from the already established joint ventures for Konrad 1 and Konrad 2 shafts (ASK 1 and ASK 2) the JV Konrad North Section (AKN) and the JV Stowage Processing Batch 1 (AKV 1) therefore represent the third and fourth examples of collaboration at the Salzgitter site. With the original JV operations to renovate Konrad number 1 and Konrad number 2 shafts now complete - activities that were reported in the 2010, 2012/13 and 2014/15 issues of

the THYSSEN MINING Report - the JVs for AKN and AKV 1 are now engaged in another field of work that involves roadway drivage and strata consolidation.

### ■ Background

Konrad mine near the city of Salzgitter was developed as an iron-ore mine by Salzgitter AG during the period 1957 to 1962. Production commenced soon after, but was halted again in 1976 for economic reasons. Investigations carried out by the then Society for Radiation and Environmental Research later certified the mine as offering good conditions for the final storage of radioactive waste with negligible heat generation. A planning approval process was then initiated on 31 August 1982 and as a result of this a non-contestable planning decision was taken in 26 March 2007. DBE was



commissioned by the Federal Office for Radiation Protection (BfS) to undertake the mine conversion work.

### ■ Construction work at Konrad 1 shaft

The contract defined the key tasks for ASK 1 as follows:

- replacement of the existing fittings in Konrad 1 shaft with a more resistant system of guides and buntons
- renewal of cables and pipework
- renovation of the Konrad 1 shaft column and insets.

Work has now been completed in the southern compartment of Konrad 1. This involved renovating the shaft lining by replacing the old grouted joints, removing the old wooden guide fittings and installing new cable runs and steel guides. Since this operation concluded ASK 1 has been taking a scheduled rest break as in-shaft winding is transferred from the north compartment to the south.

When work resumes the north compartment will get the same treatment as the south, namely replacement of the old wooden fittings with a new set of shaft guides and renovation of the brickwork lining. New shaft cables and pipes will also be installed. Once all this work has been completed Konrad 1 shaft will be handed over, as prescribed in the planning decision, to operate as a materials and manwinding shaft and transport route for the material excavated from the various heading and tunnelling activities, and to serve as a downcast ventilation shaft.

### ■ Renovation of Konrad 2 shaft and adjacent shaft inset areas

The main aspects of the ASK 2 operations were:

- renovation of the lining in Konrad 2 shaft

- construction of the shaft landing on level 2
- renovation of the landing on level 3
- extension of the existing crosscut on level 2
- excavation of part of the emplacement/transport road
- reconstruction of the shaft cellar.

Some of part-projects involved have already been successfully completed since the last Mining Report was published, such as the drivages for the shaft inset extension and emplacement/transport road. Both these zones are now subject to a waiting period, as specified by the client, for the measurement and interpretation of any further convergence movements. Other activities include the installation of two 4" pipes for the supply of building materials, the laying of a 27/8" service-water pipe and the extension of the existing 5½" in-shaft pipe. The small manwinding installation was upgraded by replacing the old rope-tension frame in the shaft sump with a new travelling tension frame. The winding regime could therefore be adapted to suit any particular set of operating conditions as the project advanced.

Every aspect of the operation first required approval planning and manufacturer-specific production scheduling for the different items of plant and equipment to be installed. Approval was also needed for the various building and engineering measures being proposed.

When drawing up the approval plans a number of problems arose in connection with the concept of a parallel working system at various points in the shaft. This would have meant using several safety platforms to divide the shaft into part-sections and then installing three small manwinding systems and three travelling stages in order to carry out the work in the shaft. This concept has now been rejected.

The new plan proposes using the existing working platform along with two new dirt conveying platforms, operating at level 2, for transporting the lava-gravel backfill. The work of constructing the landing on level 2 was carried out from the lava-gravel embankment, the excavated material being dispatched to level 3 via a gravity pipe. There are no longer any plans for a parallel system of working at several points in the shaft. Despite losing the option for working in parallel at several different places, the decrease in the number of shaft guides and fittings did in fact lead to a marked reduction in the overall workload.

The renovation work undertaken to date has involved the removal of the old rope-tension frame in the shaft sump and its replacement by a travelling rope-tension frame and the filling-in of the sump with mining dirt. The next step will be to install the dirt conveying platforms in the shaft.

Road Section profile with bolted support





Shaft tower Konrad shaft I, view from west



Shaft tower Konrad shaft 1

As difficult strata conditions are anticipated during the construction of the landing on level 2 this cavity is to be created in three stages (crown, bench and floor) using the New Austrian Tunnelling Method (NATM). In order to meet the requirement for minimum rock degradation a demolition robot was used for the heading work. The support system employed for the landing was installed using the technique described in previous issues of Mining Report.

### ■ Renovation of the northern roadway and parallel ventilation heading

During the years 1962 to 1965 the northern roadway and parallel ventilation heading were both driven at a depth of about 1,200 m in order to explore the ore bed. These areas are to be stowed as part of the mine conversion operation. However, because of the condition of these roadways certain stabilisation measures have to be put in place before the filling work can commence. This involves the removal of various fittings and fixtures.

Further consolidation was carried out by securing the roadways with expansion-sleeve bolts and weldmesh lagging. In addition, work was also needed to rectify the floor lift problem that had affected the north roadway since 1965 and to ensure that a minimum height of 2.8 m was available over the entire length of the tunnel. The debris produced from this operation was used to fill one of the sump pits. This stowing operation required the laying of a pneumatic pipe that ran from the parallel heading to the face of the north roadway.

With a total duration of just 23 weeks this particular AKN operation was obviously fairly small in scale. Nevertheless, the work was concluded successfully in 2016.

### ■ Excavation of the stowage processing zone

The main contractual tasks for AKV 1 were as follows:

- excavation of the pre-crushing zone
- excavation of transformer room I
- excavation of the bunker area
- excavation of the turnaround loop with cleaning station
- re-cutting of a section of roadway
- creation of a ventilation borehole.

Since the contract was awarded to AKV 1 at the beginning of 2016 the operation has mainly focused on the preparation and equipping of the construction site and on the provision of training and instruction sessions for the site personnel. Work has now started on the excavation of the turnaround on level 3 and on the re-cutting of part of the roadway on mine level 2.

### ■ Conclusions

The high level of public interest in Konrad mine and the current process under way to convert the facility into a final repository for low- and medium-level radioactive waste calls for scrupulous preliminary planning as well as strict compliance with the regulatory framework. The experience that the project partners have acquired over six years of working on this challenging undertaking is reflected in the professional approach that has been taken by all concerned when dealing with the problems arising.

*Jens-Michael Kopmann  
Clemens Mock  
Thomas Dreyszas  
Hubertus Kahl*





Mikwan Well 4-24 Site – Red Deer River Valley near Stettler, Alberta

# Mikwan Well 4-24 recovery project

## ■ Background

While reviewing its well production logs, a major Calgary, Alberta based integrated oil and gas company (“the Company”) noted irregularities in production well “Mikwan 4-24”. Down hole measurements, analysis, and geotechnical investigations indicated that the well casing had deformed at approximately 35 meters (115 feet) below surface. This deformation likely occurred as a result of a slow-moving yet substantial landslide of the river valley caused by excessive rain and snow melt. The Company had found that the slip had progressed 6mm (0.25in) and was increasing at a rate of approximately 0.1 mm/day or 36.5 mm/year (1.5in/year). On that basis, the well casing was confirmed to be sheared and the loss of well integrity was reported to the Alberta Energy Regulator. The site was partially decommissioned in early 2015 at which time the Company determined that a non-routine abandonment strategy was required for the Mikwan 4-24 Well.

## ■ Award of Contract

As a result of Thyssen Mining’s success with Penn West Petroleum’s Swan Hills Oil Well Casing Repair Project in 2012, The Company approached Thyssen Mining to assist with the non-routine abandonment work for the Mikwan 4-24 Well. Thyssen Mining was awarded the contract in early 2015 and immediately began with engineering efforts related to the

setup and sinking of a small diameter, steel lined shaft through frozen overburden down to the projected shear zone.

## ■ Overall Construction Methodology

In light of the nature of the water saturated overburden, Thyssen Mining was presented with an opportunity to showcase a small freeze project for the Company abandonment application. The overall plan consisted of ground freezing to just below the anticipated shear zone depth, followed by sequential excavation and steel lining of the frozen overburden. Thyssen Mining planned to utilize a combination of a shaft mucker and mucker tower for the pre-sink and a shaft mucker and hoisting plant and headframe arrangement for the main sink. The frozen ground around the well head was to be excavated and steel lined to a depth of approximately 50 meters (165 feet). Thyssen Mining would then assist the Company with the removal of the damaged well casing and installation of a new casing extending to the surface grade.

## ■ Freeze Hole Drilling

Initial planning and design for the freeze setup began in July of 2015.

The design consisted of fourteen freeze holes to be drilled in a circular manner centered around the well casing. Two additional holes were to be located slightly outside the

freeze hole perimeter. These additional holes (drilled and cased) would be used as temperature monitoring holes. Elk Point Drilling, of Spruce Grove, Alberta, was sub-contracted for drilling the freeze holes and installing the steel casings.

Each hole was drilled to a final approximate depth of 60 meters ( $\approx 197$  feet) and was cased with standard J55 steel casing.

Vertical drilling accuracy is very important, as even a slight deviation over great lengths, can cause the freeze holes to wander into the excavated shaft area.

Upon completion of the cased freeze holes, a wire line survey was carried out to ensure the accuracy of the drilled holes. The steel casings were then capped and pressure tested to 1.0 MPa ( $\approx 140$  PSI), ready to be connected to the freeze headers, brine distribution system and mobile freeze plant.

### ■ Collar Construction

Before ground freezing could begin, the shaft collar area was excavated, formed, and poured with a 30 MPa ( $\approx 4,500$  PSI) concrete mix to establish both a freeze cellar and a foundation for a Clam Tower and Portable Headframe structure. Armtex corrugated steel liner plate, used for the formwork for the freeze cellar and collar foundation work, was installed to an initial depth of 2.5 meters (8'-2").

With the collar foundation and freeze cellar completed, the freeze pipes were outfitted with headers and connected to a brine distribution system. A refrigeration sub-contractor was utilized to assist with the installation, commissioning, maintenance, and continual monitoring of the freeze system during ground freezing and shaft sinking operations.



120TR Mobile freeze plant at Mikwan Well Site

Once the freeze system was turned on, a Clam Tower structure was installed on its foundation near the edge of the shaft. The purpose of the Clam Tower, in conjunction with a Cryderman Shaft Mucker, crane and sinking bucket, was to provide a means of mucking the shaft during the pre-sink. The pre-sink depth was designed to ensure the Galloway work stage could be safely installed and remain in the shaft. During the pre-sink, the vertical shaft mucking unit was used to load a 2.0 m<sup>3</sup> (2.5 yd<sup>3</sup>) sinking bucket. Once loaded, a mobile crane was used to hoist the bucket to surface to dump the muck in the designated waste storage area.

### ■ Shaft Excavation – Pre-Sink

As the shaft was excavated, corrugated steel liner plate and ring beams were installed in order to provide ground support.

As an additional means of ground support, the annulus between the excavation and the corrugated steel liner plate was backfilled with a lean concrete mix.

Pre-sink operations continued to a depth of approximately 20 meters ( $\approx 66$  feet). As the pre-sink advanced, the well casing was cut and removed in 2.0 meter (6'-6") sections.



Elk point drill rig setup and ready to drill





Beginning of the construction for the freeze cellar



Shaft collar foundation and freeze cellar



Clam tower structure used during pre-sink

Concurrent with the pre-sink, a Galloway work stage was assembled on surface. Once the pre-sink was completed, the Clam Tower structure was removed and the Galloway work stage was placed on shaft bottom. A Portable Headframe structure was erected over the shaft and a hoist and two stage winches were installed and commissioned accordingly. Guide ropes from the two stage winches were used to suspend the Galloway in the shaft and also doubled as a means of conveyance guidance. A sinking bucket was connected to the main hoist as the primary means of mucking and egress from the shaft.

The Galloway work stage provided a second means of egress and a small emergency hoist was installed as a tertiary means of egress at the client's request.

A winch was installed on the collar steel and used to suspend the Cryderman mucker in the shaft during the main sink mucking operations.

#### ■ Shaft Excavation – Main Sink

The main sink continued to the location of the well casing shear zone. The shear zone was reached at a depth of approximately 35 meters (≈115 feet).

After client inspection of the well casing at the shear zone, it was decided that the Company would coordinate the installation of a new well casing and backfill (utilizing previously excavated material) to surface grade.

#### ■ Demobilization & Project Closeout

Full demobilization commenced in December of 2015 and was completed within two weeks.

The Thyssen Mining Project Team was comprised of eighteen employees split between two twelve hour shifts per day. The onsite management team was comprised of a Project Manager, Project Engineer, and a Safety Coordinator. The shaft crew was comprised of a Shaft Leader (supervisor), Clam Operator, Shaft Miner, Deckman, Hoistman, Freeze Plant Operator, Mechanic and an Electrician.

At the conclusion of the Mikwan Well 4-24 Recovery Project, the Company presented the Alberta Energy Regulators with a report outlining the project from the design and planning phases to the onsite execution and abandonment phases. The intent of this report was to help establish a precedent in Alberta, amongst all oil and gas companies, for both the recovery and non-routine abandonment of damaged or

Shaft during the pre-sink phasis



deformed well casings utilizing the Thyssen Mining ground freezing and shaft excavation methodology as executed at the Mikwan Well 4-24 Recovery Project.

The Mikwan Well 4-24 Recovery Project is a successful example that outlines the importance of working closely with a client to safely deliver quality service and build a lasting relationship.

The request from the Company to assist with the non-routine abandonment work for the Mikwan 4-24 Well was a direct result Thyssen Mining’s success at Penn West Petroleum’s Swan Hills Project.

As a result, of the careful planning and well executed work conducted for this project, Thyssen Mining has become the contractor of choice for projects of this nature in Alberta’s oil and gas industry.

Thyssen Mining is recognized for bringing practical and value-added solutions to complex and difficult projects beyond the traditional “mining industry”.

*Md Abu Zahid*



Two deck galloway work stage



Picture right:  
Shaft during main sink

The company & Alberta Energy Regulators Group – site visit after installation of the portable headframe and hoisting plant







McArthur River Shaft #2 – Northern Saskatchewan

# Maximizing the life expectancy of an uranium mine

## ■ Background

Cameco Corporation (Cameco), based in Saskatoon, Saskatchewan, is the world's largest publicly traded uranium company and the world's second largest uranium producer, accounting for 16 % of world uranium production. Cameco's McArthur River Operation is the world's largest high-grade uranium mine located in Northern Saskatchewan, approximately 620 km north of Saskatoon.

As part of Cameco's Shaft #4 Ventilation Optimization Project, Thyssen Mining was approached in early 2014 to assist with a pre-feasibility study relating to increasing the overall mine

ventilation at the McArthur River Operation. The study included an assessment of the Shaft #2 infrastructure and ventilation capabilities in an attempt to develop an executable construction strategy that aligned with Cameco's objectives during a narrow operational shutdown window.

Shaft #2 (approximately 6.0 meter (20 feet) diameter and 530 meter (1,750 feet) depth) was being used as a ventilation shaft (exhaust). The shaft contained old (unused) steel furnishings which included, a manway, steel sets spaced at 6.0 meter (20 feet) intervals for a cage compartment, various shaft brackets, twin 200 mm (8 inch) concrete slick lines, and a 2.1 meter diameter (7 feet) ventilation duct all of which extended the full length of the shaft.

New portable headframe structure at paint shop



The steel furnishings were required to be removed in order to enable increased ventilation rates in the shaft. It was estimated that by removing the old steel furnishings from the shaft, the effective cross sectional area of the shaft could be increased by approximately 15 %.

Upon completion of the study, Cameco had decided that in order to continue the growth of their current operations at the McArthur River Mine Site, they were going to have to proceed with the Shaft #2 remediation work in order to increase the overall mine ventilation. The most opportune time to complete this work would be during a shutdown period planned from August through to October, 2015. Once

completed, it was estimated that the overall mine ventilation capacity would increase from approximately 600,000 cubic feet per minute to 650,000 cubic feet per minute.

### ■ Award of Contract

Thyssen Mining, through one of its joint venture partners Mudjatic Thyssen Mining (MTM), was awarded the Shaft #2 Remediation contract in late May of 2015. Detailed design and engineering efforts began immediately as did the construction of a new Portable Headframe Structure.

The Portable Headframe functions much like a traditional steel headframe but can easily be erected and dismantled in a fraction of the time and cost. Given the narrow timeframe of the planned shutdown, it was decided that a Portable Headframe would be ideal for the Shaft #2 Remediation Project.

Detailed engineering and fabrication efforts consisted of the following:

- Portable Headframe Structure and respective Foundation,
- Clam Tower Structure modifications to accommodate Material Hoist,
- Two Deck Galloway Work Stage,
- Permanent Collar/Sub-Collar Steel and respective Foundation,
- Permanent Ventilation Elbow and Transition (to reconnect to existing infrastructure)
- Maintenance Cage, Sinking Bucket, and Gear Basket,
- Complete electrical and mechanical rebuild of Timberland Man-Hoist,
- Hoist Operators Cubicle,
- Complete mechanical rebuild of Timberland Galloway Winch (x2),
- Complete electrical and mechanical rebuild of Timberland Emergency / Material Hoist
- Various Head and Stage Sheaves,
- Water Capture/Control System
- Various Shaft Brackets, and
- Various Service Handling Clamps for steel and timber removal from shaft.

### ■ Mobilization and Surface Setup

Mobilization to the McArthur River Site began at the end of July of 2015. In less than three weeks, site preparation and initial setup, installation of all shaft plant and support equipment, and the erection of the Portable Headframe was completed.

The site preparation and initial setup work included the following:



New maintenance cage ready to ship upon completion of plumb test

- Removing existing collar and sub-collar concrete and steel by means of saw cutting into manageable sized pieces,
- Removal of existing surface mounted ventilation ducting to allow for the installation of the shaft plant equipment, and
- Forming and pouring a new collar and respective shaft plant foundations.

Removal of existing collar and sub-collar concrete and steel beams







Installation of permanent collar steel and galloway work stage at shaft #2



View from galloway – existing water inflow and steel furnishings

Shaft furnishings hoisted to surface and removed



The installation of shaft plant and support equipment included the following:

- Office / Lunch Trailer
- Various Sea Containers
- Permanent Collar Steel c/w Temporary Collar Door
- Two Deck Galloway Work Stage
- Portable Headframe Structure and Material Handling Tower Structure
- Timberland Man-Hoist c/w Hoist Operator's Cubicle
- Timberland Emergency / Material Hoist
- Timberland Galloway Winch (x2)
- Ingersoll Rand Tugger (x2)
- Sullair Air Compressor (x2) c/w Air Receiver Tank

Following the installation of the Galloway and Permanent Collar Steel, the Portable Headframe, Material Handling Tower Structures, Hoists and Winches and respective conveyances (sheaves, wire ropes and rope end attachments) were commissioned, both electrically and mechanically, and ready for operation.

#### ■ Shaft Work

On August 19, 2015 the first steel set was removed from the shaft. Removal of the shaft furnishings was accomplished by utilizing a series of small tuggers to transfer the steel furnishings from the concrete shaft liner to the hoist rope(s) where they were hoisted to surface and disposed of accordingly.

Each set consisted of two concrete slick lines, a large ventilation duct, steel bunton brackets and accompanying support steel and brattice, a set of timber guides, and a man way equipped with a ladder and landing every 6.0 meters (20 feet) in the shaft.

In order to maximize air flow in the shaft, it was necessary to capture as much of the ground water leaking into the shaft through existing cold joint as possible.

As the steel furnishings were removed, the water inflow was assessed and a water capture system was installed. The water capture system varied depending on the nature and location of the inflow but generally consisted of drilling a series of holes through the concrete shaft liner into the adjacent rock and installing a water collection piping system similar to a French drain. Once secured to the wall the collection piping and hosing was routed into a 200 mm (8 inch) drain line.



View from galloway – water capture system



View from galloway – water capture system near shaft bottom

Once the existing shaft furnishings were fully removed and the water capture system installed, the Galloway Work Stage was lowered to the shaft bottom where it was dismantled and hoisted to surface in small pieces.

With the shaft work completed, de-mobilization of the shaft plant and support equipment was underway. Once all equipment was removed from the shaft collar area, the permanent ventilation elbow and horizontal transition were installed to re-connect Fan #4 to the shaft ventilation system. The Shaft #2 fans were ready to be energized on October 10, 2015, five days ahead of the planned shutdown schedule.

### ■ Ventilation Elbow and Horizontal Transition

Over the course of a forty-five day period, the MTM site project team installed a shaft Water Control System and removed eighty-seven steel sets, totaling approximately one hundred and eighty (180) tons of steel.

The MTM site project team consisted of nineteen employees split between two twelve hour shifts per day. Site management included one Project Manager, one Project Engineer, and one Safety Coordinator. Each shaft crew consisted of two (Shift Supervisors, six Shaft Miners, four Deckmen, and two Hoistmen; one Mechanic and one Electrician worked dayshift only.

In less than eleven weeks, MTM was able to safely and efficiently execute the scope of work in the desired timeframe as dictated by Cameco's shutdown schedule. As a result, the overall ventilation increased to almost 770,000 cubic feet per minute, which was 120,000 cubic feet per minute more than what was originally expected.

*Kayne Ulmer  
Jordan Forbes*

De-mobilization and elbow installation







Interior and installations in the entrance of the Metro Station

## Stopping leaks in Manhattan

**Sovereign-Thyssen L.P. (STLP) manufactures and installs NOH2O, a proprietary and patented polymer-based emulsion. NOH2O has an extremely low viscosity and a particle size of less than one micron. Because of these characteristics, it is miscible in water and succeeds in cutting off leaks under conditions where other grouting systems fail.**

STLP first began working for New York City's Metropolitan Transportation Authority (MTA) in 2010, when hired by the General Contractor to grout off a leak of 1000 liter/minute between the base of a slurry wall and the top of rock at a launch pit for the East Side Access Project. STLP successfully used NOH2O to stop the leak, a goal that had eluded every other grouting contractor and product that the General Contractor had called in previously. Since then, STLP has grouted off leaks for MTA in projects of increasing complexity, most recently at the Hudson Yards Station.

New York City Transit's Hudson Yards Station opened in September 2015, a new terminus for the 7 line and an access point to a recently completed section of the High Line and to the remodeled Jacob Javitz Center. Developers were working on new residential and office towers nearby. After a few months of station operation, patrons complained about water dripping through ceiling panels over the entrance escalators.

Only one entrance, referred to as "Site J", was initially used. The entrance structures are shown schematically in Figure 1. This entrance features two reinforced concrete arches which are inclined to span from Mezzanine to Concourse level (roughly 60-ft difference in elevation). The south inclined tunnel (E1) features one escalator and two inclined elevators. The north inclined tunnel (E2) features four escalators.

Unable to shut down either incline, the Metropolitan Transportation Authority (MTA) chose to address these drips at night during off-peak hours. The General Contractor called on STLP to seal off all ongoing leaks throughout the Site J

structures. The leaks of primary concern were those dripping from the crowns and on through the perforated ceiling panels of the E1 and E2 inclined tunnels, but there were also leaks in non-public areas on the Concourse level and in personnel staircases to be treated.

Primary grouting operations started in late March 2016. Initial treatment began with the installation of a curtain cutoff barrier formed of NOH20 at the vertical endwall along Gridline "E" which topped both inclined tunnels, to prevent displacing water up the incline and into the station entrance. Once the barrier was complete, a series of holes was drilled through the reinforced concrete arch along the inclined tunnels and grouted sequentially from the low end, starting with the north tunnel (E2) followed by the south tunnel (E1). This first push to seal leaks along the inclined tunnels above the escalators required four six-day weeks, with grouting work taking place at night and periodic monitoring during the daytime for possible reports. Altogether, 68 holes were drilled (24 in the endwall and 22 in each of the inclined tunnels) and 23,250 liters of NOH20 were pumped, to cover an area of 2,000 square meters.

Before STLP was called in, the General Contractor had tried to grout off the leaks using several hydrophobic polyurethanes and a multi-component methacrylate resin. During NOH20 injection, an unusual report was observed to a nearby construction joint. The material was a murky white liquid which was later identified as the B-component of the methacrylate resin, which had been injected unreacted and remained dormant in voids adjacent to the tunnel annulus until it was pushed out by the NOH20 grouting pressures.

After the inclined tunnels were grouted, the non-public areas were addressed. A consequence of grouting the inclined tunnels was that some water migrated to the landing of E1 tunnel. Ceiling panels were removed there and holes were drilled through the liner. Several of the holes intercepted a void behind the liner which was channeling much of the

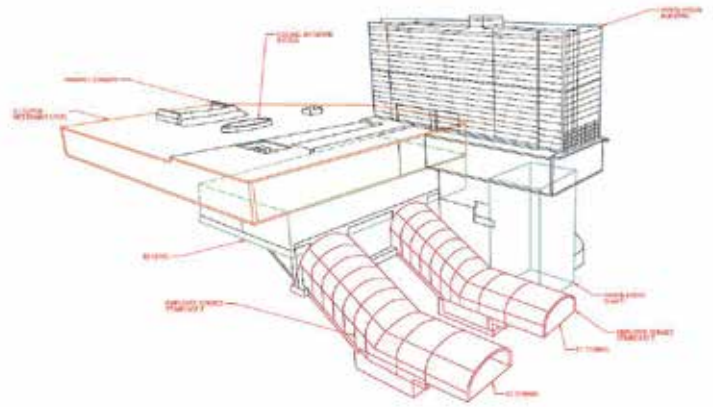

Schematic 3D image of the Hudson Yards Station "Site J" entrance

groundwater to this area. These holes were allowed to drain overnight and were grouted soon after. In total, 225 holes were drilled during production grouting and 28,964 liters of NOH20 were pumped from the end of March to the middle of June 2016, treating 2,600 square meters. The leaks above both escalator inclines were eliminated, and station service continued uninterrupted throughout the duration of treatment.

STLP has produced dry underground civil structures where other firms, products and processes have failed and is now working at a number of sites for the MTA and for other New York City authorities charged with the maintenance of tunnels and other underground facilities.

*John Minturn*

Concrete covering after successful grouting work







Freeze machine containers



Isolated distribution pipes between freeze machines and shaft

## Megaproject 'Freeze plant for Gremyachinski mine'

**The freeze shaft construction site at Gremyachinski near the town of Kotelnikovo in the province of Volgograd is in many respects a project of superlatives. The freeze sinking technique is currently being used at the mine to construct three shafts for the client EuroChem-VolgaKali. With each of the three shafts requiring a freeze depth of up to 820 m the operation presented an extremely demanding engineering challenge for contractors THYSSEN SCHACHTBAU. What set the project apart from other assignments was the fact that the three shafts all had to be constructed simultaneously at the same mine site and to such a large freeze depth.**

Between early 2010 and 2012 THYSSEN SCHACHTBAU successfully completed a ground freeze for the skip shaft (SK1) at Gremyachinski. The freeze depth required in this case, in the light of information available at the time, was 520 m. Further exploration then produced new hydro-geological data on the deeper lying, water-bearing horizons below the 520 m sinking floor. The freeze plant at SK1 shaft subsequently had to be extended in order to seal and stabilise the water-bearing rock lying between the 520 m and 820 m levels. A second larger freeze ring also based on 44 pipes was established at the SK1 shaft and the freeze operation subsequently commenced in July 2013. The new hydro-geological information on the deeper lying, water-bearing

horizons was factored directly into the plans for number 2 skip shaft (SK2) and for the service shaft (SES). The operation to freeze all three shaft columns simultaneously to a depth of 820 m commenced in July 2013.

In order to freeze the three shafts the total refrigeration output of the freeze plant was increased to 10.5 megawatts. This is equivalent to the average electricity requirement of some 18,000 four-person households. When the project commenced the freeze plant comprised ten freeze machines. Before commissioning the two additional shafts an extra freeze station was installed with nine additional freeze machines. The surface facilities now extend over an area the equivalent of six football pitches.

At peak times 28 centrifugal pumps are circulating some 1,500 m<sup>3</sup> of coolant through the pipes at 16 bar and 2,100 m<sup>3</sup>/h. This extracts the thermal energy from the strata that is needed to create a totally enclosed, solid and stable ice wall. The surface supply pipes have a total length of around 1.5 km while the subsurface freeze pipes laid below ground cover a combined distance of 120 km. The freeze wall that develops from these pipes protects the unsupported shaft column from collapsing during the sinking process and also seals it against water ingress.

The geological formations in the freeze zone are extremely varied and inconsistent. The lithological sequence contains areas of loose, unconsolidated material, such as sands, as well as stable sections of solid rock. The most critical zones comprised strata containing swellable clay minerals that on contact with water not only swell out but also have a tendency towards plastification. This material can seriously compromise the shaft sinking operation. The ground freeze process effectively stabilises these highly problematic and unstable areas so that they can then be worked through without any complications.

Fibre optic transmission technology was used to generate all-round temperature profiles of the advancing freeze column from a total of 12 instrumented boreholes. These measurement points are used for the direct observation of rock temperature trends and can in addition recognise heat sources emanating from within the shaft column (for example as a result of ventilation or heat of hydration from the concrete). External influences from the surrounding strata, such as local ground-water flows, can also be pinpointed by means of the temperature measurements.

It is also interesting to observe the varying temperature trends within the different rock types. Thermophysical

properties affect the behaviour of the freeze process just as much as does the water content of the rock.

Thanks to the application of modern numerical software it is now possible to replicate, process and resolve all manner of specific and complex problems associated with ground freezing operations. The ability to make temperature-trend prognoses for the different strata horizons is very useful here. Taking as a reference the actual distances between the freeze pipes and the rock temperatures as measured around each shaft column it is possible to construct two-dimensional and three-dimensional numerical models. Here it is essential to establish a continuous comparison between the models and the actual temperatures measured in the strata.

With the freeze plant in continuous operation SK1 shaft safely reached the bottom of the freeze zone at 820 m in November 2014. There were no water incursions. SK2 shaft also successfully passed through the ice wall and reached the non-frozen zone after just less than 1,000 freeze days. In the service shaft the sinking floor has nearly reached the end of the freeze zone.

All the operating parameters associated with the complex and continuously modified and extended freeze plant were

TS employees controlling the freeze plant







Operator's position for the controlling and timing of the freeze plant



TS employees planning a reconstruction

constantly displayed and monitored. Our specialist technicians remained on site and attended to the equipment every day round the clock to ensure that the plant operated smoothly and efficiently and with the minimum of interruptions. Staff back home at the control base in Mülheim were able to monitor events by remote access and could provide support to their colleagues on site if necessary.

Before the freeze plant could be permanently shut down the shafts still had to be fitted with a long-term watertight inner

lining. This involved installing cast-iron tubing segments and fixing them to the surrounding strata with concrete backfill. These segments featured injection holes through which any gaps and fissures in the concrete and in the adjoining strata could be sealed. When this sealing work had been successfully completed the freeze machines could finally be decommissioned.

Since the start of the ground freeze process the entire freeze plant has undergone a continuous metamorphosis involving all manner of alterations and adjustments that to this day have posed a demanding and fascinating challenge for the THYSSEN SCHACHTBAU team. Plans are even now being laid for the conversion of ten freeze machines and two energy containers, which will involve relaying the power supply lines and pipes. This conversion work is to be undertaken while the freeze process is under way. This in an operation that will require real expertise and some careful planning, the engineering equivalent of open-heart surgery.

### ■ Summary

Thanks to the successful execution of the ground freeze operation by the THYSSEN SCHACHTBAU team the client, EuroChem-VolgaKali, was able to sink the Gremyachinski SK1 and SK2 shafts through the unstable, water-bearing horizons to reach the 820 m-level and then to complete the shaft lining work. The sinking operation was carried out safely and without water incursions. The freeze technique had once again proved its reliability and effectiveness as a specialised procedure for the shaft sinking industry. The freeze process can be seen in stark contrast to the less than successful sealing operation that was conducted at the SES shaft using the grout injection method. This attempt had to be abandoned at the end of 2012 and was replaced by a ground freeze system. THYSSEN SCHACHTBAU has now been engaged in this exciting project since 2009, an undertaking that has seen the company and the client EuroChem-VolgaKali enter whole new dimensions in the field of freeze shaft construction.

*Tim van Heyden  
Björn Wegner*

# Joint Venture for the exploration of potash and phosphate deposits in the Russian Federation

**EuroChem of Moscow and THYSSEN SCHACHTBAU GMBH (TS) have created a Russian based joint venture company under the name “Thyssen Schachtbau EuroChem Bohren” (TEB).**

**TEB will focus primarily on exploration drilling projects for the EuroChem Mineral and Chemical Company (EC).**

The joint venture came about in response to the fact that Russia lacks the technology necessary for the exploration of potash deposits. EC, a fertiliser manufacturer headed by Andrei Melnichenko and Dimitri Streznev, and TS, a mining contractor owned by Claudio Count Zichy-Thyssen, set up the joint venture in 2015. The two partners have therefore joined in with the current market trend that is actively driving company mergers and take-overs in the drilling sector. The Russian Federation in particular has recently witnessed a series of partnership agreements and joint-company launches. EC is one of Russia’s leading fertiliser manufacturers and the fourth-largest producer worldwide. They produce a full range of fertiliser products that include phosphate, potash and nitrogen fertilisers.

The formation of TEB will help EC strengthen their partnership with TS in the long term and will serve to mitigate price risks. For TS the joint venture creates an opportunity to maintain a presence in the Russian Federation and to play an active role in drilling activities in the country for approximately the next ten years. It is predicted that the annual exploration drilling requirements will be in the order of 20,000 metres of borehole.

The joint venture will handle the drilling and safeguarding of the boreholes. In the medium term, the boreholes will also serve as the basis for conducting geophysical investigations. The drilling services will be delivered on a turnkey basis and will include all preparatory work required to set up the drilling area. Services will also include all post-drilling operations needed to dismantle the plant and equipment, including the restoration and recultivation of the borehole drilling site.

The drilling projects will primarily be carried out at EC sites located in three districts: Saratov (deposits at Sapadno-

Perelyubsky and Vostochno-Perelyubsky), Kotelnikovo (Gremyachinsky deposits) and Verkhnekamsky (the Belopashinsky deposits).

Although fertiliser manufacturers and exporters have generally been less affected by the global raw-materials downturn, the establishment of a joint venture is a logical step. Given the general downturn in the investment cycle and the fact that drilling-company mergers and take-overs are now being actively pursued in this market segment, the joint venture serves to benefit both parties.

Even before the TEB joint venture was announced industry analysts that follow EC’s activities were speculating about collaborations with overseas drilling companies operating in this market. The industry analysts suggested that collaborations have come about because Russia has not had a green-field potash mining project in over 40 years and the country lacks modern technology in the field.

TEB has its head office in Kotelnikovo, a southern administrative district of Volgograd, has a workforce of over 120 individuals and is equipped with five deep drilling rigs.

*Robert Handke  
Rolf Krause  
Felix Karpov*

Drilling crew and administration members







## Starting again – shaft number 3 beckons!

**Between June 2010 and July 2014 THYSSEN SCHACHTBAU GMBH (TS) delivered a contract for EuroChem (EC), the Russian chemicals company, which involved operations at two shafts serving the Palasherskij mine in the Perm region. This work comprised drilling and ground freezing operations, artificial thawing of the strata and the injection of long-term infill (liquidation) into the freeze holes. At the beginning of 2016 EC once again commissioned TS to provide the same package of services for the third shaft at the same mine. The ground freeze operation subsequently began in October 2016.**

TS can look back on a longstanding and successful collaboration with EC, which operates mines in the Perm and Volgograd regions. Since 2009 TS has been involved in various activities associated with ground freeze operations at both mining sites and has successfully met the demanding requirements and specifications laid down by the client. Our team of specialists has been able to provide a comprehensive range of services, beginning with design planning and the preparation of approval documents through to the practical execution of the freeze-hole drilling programme, the actual

ground freeze itself and, finally, the artificial thawing of the strata and the liquidation of the freeze holes.

It was a moment of great joy at TS headquarters when the contract for the aforementioned work was signed by both parties in early 2016. The highly skilled team of specialists who had already been responsible for the smooth operation of the drilling, freezing and thawing technology on site were upbeat as they looked forward to another deployment in the field.

When the green light was given to commence the freeze on 25.10.2016, after the freeze holes had been drilled and the refrigeration plant assembled, the team watched as the ground temperatures plummeted around the shaft column – and not just there, for above ground too things became extremely cold as temperatures fell to minus 30 °C. The coolant was pumped in closed circuit through 41 freeze pipes to a depth of 270 m, resulting in a very rapid cooling of the surrounding strata.

TS had made an early start on the preparation work, with the result that drilling operations for the freeze holes were able

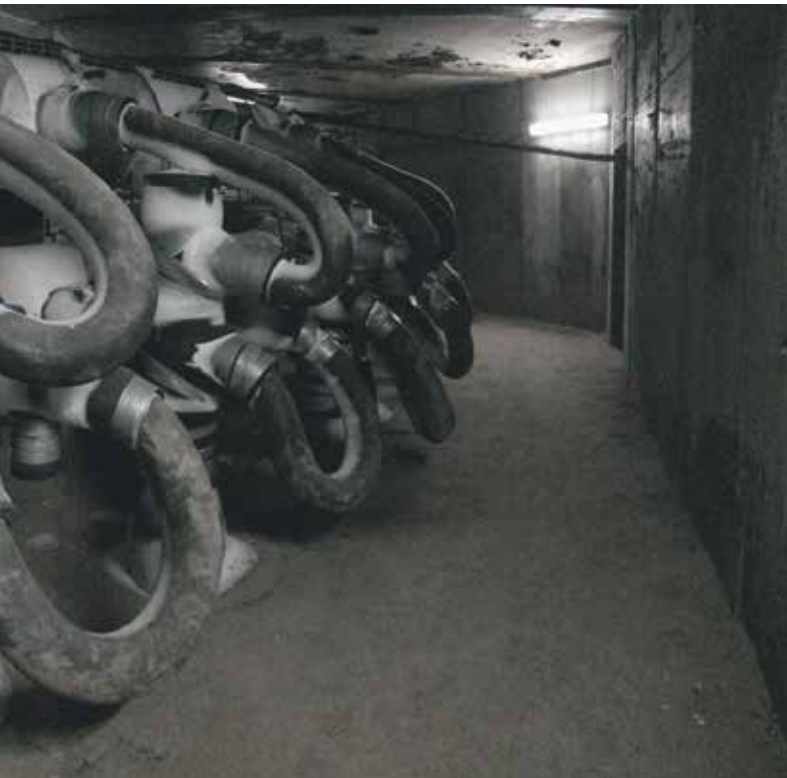

Ice formation at the freeze pipe heads



Pic. top right:  
Operators position



Pic. down right:  
TS employees controlling the  
freeze plant

to commence in mid-February 2016. The third shaft at Palasherskij mine was to serve as a second winding shaft. The original freeze plant had been designed for the simultaneous freezing of shafts 1 and 2, whereas the plant that was now to be set up, which had a refrigeration output

of about 1,800 kW, was only required for a single freeze. As was the case at shafts number 1 and 2, and following the installation of the tubbings that would provide the permanent shaft lining, the freeze equipment could be converted from freeze to artificial thaw mode in a very short space of time.







Freezing plant just before Christmas

This facility was possible because of the modular structure of the ground cooling and ground heating machines. This allowed some of the refrigeration units to be replaced by heating machines that could be switched over immediately to heating mode. When the artificial thaw had been completed the freeze pipes were ‚liquidated‘, which involved filling both the pipes and the surrounding strata with long-duration injection material. The objective here is to seal the boreholes and create a long-term barrier that will effectively prevent any short circuit between the different ground-water horizons.

## Summary

Until today the project operates almost interference-free and to the satisfaction of the client. The total package of services for the third shaft at Palasherskij mine is expected to be completed by 2018.

*Björn Wegner  
Tim van Heyden*





View over the Gepatsch reservoir

## TIWAG commissions exploration and drainage work in the Klasgarten exploratory drift

The Kaunertal power station, which is operated by TIWAG (Tiroler Wasserkraft AG), is one of Austria's largest storage power plants. Constructed between 1961 and 1964 the installation generates power by using the 900 metre-drop in height between the valleys of Kaunertal and Inntal near the Tyrol town of Prutz.

### ■ Project description

The unstable ‚Klasgarten‘ slope runs along the Kaunertal on the eastern side of the Gepatsch reservoir. An exploratory drift has been excavated near the slope for drainage and reconnaissance purposes. The valley flanks of the Gepatsch reservoir are prone to landslip in a number of areas and are now permanently monitored following the dangerous landslide of 1964. In 2011 THYSSEN SCHACHTBAU GMBH's Austrian branch was commissioned by TIWAG to sink a total of eight exploration holes in order to examine how the complicated geological situation would be affected by a significant change in the catchment conditions at the pumped storage facility. A total of 75 drainage holes were also to be drilled from the exploratory drift to drain the slippage-prone slope.

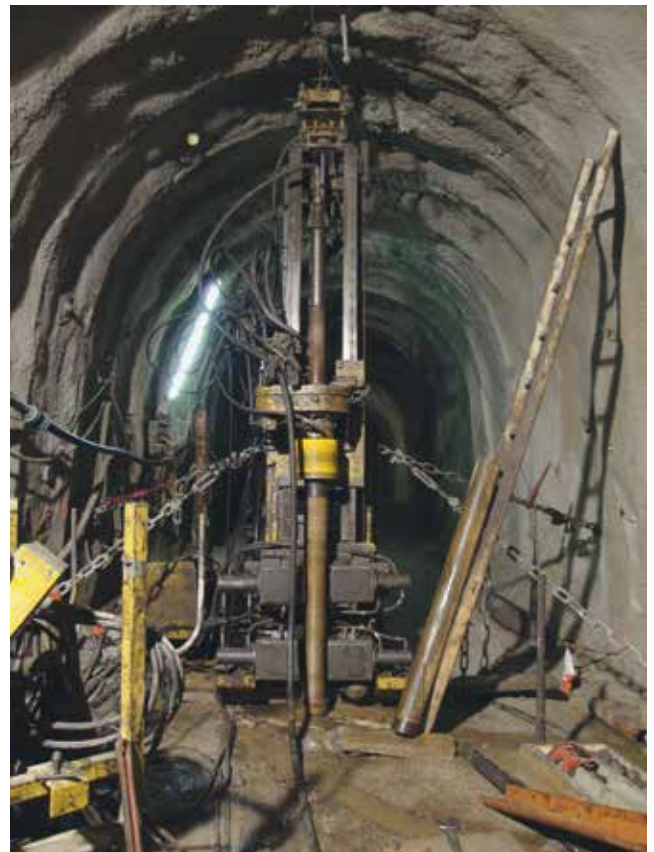

Exploration drilling into different alignments





Exploration drilling ...

The Klargarten exploratory drift is located on the true right side of the Gepatsch reservoir at a height of some 1,800 m in the upper Kaunertal valley. TS worksite, which lies at the base of the dam, is reached via the Kauner-valley glacier toll road that begins at Prutz. The drift first runs for some 100 m in a south-easterly direction before veering to the south and then continuing for a further 350 m parallel to the valley to a point directly in the centre of the landslide zone. From there it makes another 90° change in direction to continue a further 450 m to the east before ending in the area being proposed as a route for the new headrace.

### ■ Exploration drilling

The survey holes were drilled to depths of as much as 130 m using a specially adapted Atlas Copco Diamec 282 core drilling rig. The CSK 146 core barrel was able to recover cores with the required diameter of 101 mm. The relatively large hole diameter was also needed for the test equipment that would subsequently be installed inside the holes, some of which were drilled vertically and some in other alignments. These in-hole investigations included detailed geophysical measurements and hydraulic pressure tests. One unusual

Drilling with Atlas Copco drilling jumbo



... inclined into different directions

feature of this operation was the requirement for a pore-water pressure sensor to be installed inside a 100 m-deep vertical drill hole. The extremely variable geology encountered in this part of the drift made the installation of the sensor an even more laborious process, while the cramped working conditions in a tunnel cross-section of only 12 m<sup>2</sup> posed some significant technical and safety challenges for the drilling team.

### ■ Drainage holes

The 75 drainage holes, which were distributed over the entire length of the drift, were drilled 10 m deep into the water-bearing strata from various points in the right and left sidewall. This operation was undertaken using a twin-feed Atlas Copco drill jumbo that had already been deployed for tunnel drive work. Thirty of the holes, 76 mm in diameter, were fitted with hoses so that the mine water could simply be siphoned-off in a controlled manner. The remaining 45 boreholes were additionally fitted with drainage pipes running the entire length of the hole.

A system of inclinometers and extensometers was set up to monitor slope deformation in the exploration holes drilled by TS and these instruments are still in operation.

There are plans to create additional survey drifts along the eastern side of the reservoir. Our collaboration with TIWAG now includes a number of successful projects, including drilling work in the Längenthal exploration tunnel in Kühtai (Tyrol) and the completion of a 220 m-deep drilling in the Ziller valley (Tyrol). The latter drilling, which was raise-bored to a final diameter of 1.2 m, serves as a pressure-water pipe for a hydro power station.

*Tamara Portugaller  
Stefan Schichtel*



Inserting the inner core barrel into the drill string for water jetting into the depth

## Underground exploration drilling for the shaft Asse 5

Die Asse-GmbH, Remlingen, hat die THYSEN SCHACHT-BAU GMBH (TS) mit untertägigen Erkundungsbohrungen für den Schacht Asse 5 aus dem bestehenden Grubengebäude heraus beauftragt, um die Erkenntnisse aus der Erkundungsbohrung Remlingen 15 zu ergänzen.

### ■ Scope of work

The planned retrieval of the radioactive material stored at Asse II mine will require the sinking of a new shaft, (the Asse 5 shaft) with a connection to the existing underground infrastructure.

The assumed geological conditions of the saliniferous strata in the Asse salt dome are based on a limited amount of

Resetting the drill pipe during drilling operation on the 574 m-level



information and therefore may include inaccuracies. As a result of this limited, information on the position and resolution of geological structures is of great importance. The information will be crucial when selecting the site of the proposed Asse 5 shaft and for the installation of new underground chambers and mine infrastructure facilities.

For this reason, Asse selected TS to complete a series of exploration holes with core samples, drilled from the 574 m and 700 m-levels of the existing mine, towards the proposed Asse 5 shaft.

### ■ Drilling Operations

The holes are to be core drilled from the 574 m and 700 m-levels through virgin saliniferous rock towards the proposed Asse 5 shaft location. The drill holes are mostly horizontal, with several holes drilled at an inclination slightly above the horizontal, never more than 15 degrees. The final hole direction and inclination data is to be provided based on exploration results from the Remlingen 15 surface borehole, with data from the electromagnetic radar measurements.

Two exploration holes are to be drilled at each drill site, with each hole drilled to a maximum length of 350 m. It is anticipated that the boreholes will have a total length of 1,300 m. The geological information obtained from analyses of the core samples could still have a significant impact on





Drill and rod bearing on the 574 m-level

the planned exploration costs. Drilling is underway on the two holes at the 574 m-level and when this is complete, the drill will be relocated to the 700 m-level.

### ■ Drilling Plant and Drilling Technique

The exploration holes are being drilled using a Diamec 282 electrohydraulic drill rig. A HQ wireline coring system with air flushing is being used for drill core recovery. A compressor-accumulator system delivering 10 m<sup>3</sup>/min at 8 bar of compressed air is used exclusively as a flushing medium. A dust separation cyclone is used to separate the drill cuttings from the flushing medium, while a rotary feeder ensures that the particles are discharged from the cyclone.

All of the pertinent data from the drilling process is continuously displayed using a drilling-data acquisition system. The information that is displayed includes:

- Date and time
- Speed of rotation

- Torque
- Contact pressure
- Penetration rate
- Volume flow

A maximum of 2 % drilling deviation is permitted for the direction and inclination parameters. These parameters are monitored by taking control measurements of position and inclination approximately every 70 m using an electronic multi-shot system.

### ■ Safety Equipment

All of the equipment required to drill the boreholes safely and efficiently was provided by the client. The equipment was selected in order to comply with the safety standards currently defined for drilling operations at Asse II mine.

The following components are used at each drilling site (see figure showing HQ preventer stack – Asse):

1. Standpipe with lengths varying from 6 m to 20 m (Individual screw-fit sections of 1.5 m each)
2. Two borehole isolation devices (gate valves)
3. Preventer stacks (each stack comprised of two ram-type preventers and one annular preventer)
4. Kelly valve and flush head

After the standpipe is set in place and the magnesia grout is hardened, a section of core is drilled and extracted from 3 m beyond the end of the standpipe. A leakage test is then carried out with the client, where the standpipe is sealed off using a borehole isolation device (gate valve) and is loaded with a saturated salt solution.

The following test phases are carried out to verify the integrity of the standpipe:

#### Test phase 1:

- 574 m-level 70 bar (15 min)
- 700 m-level 85 bar (15 min)

Explosion and gas protection measures for underground exploration drilling in virgin saliniferous strata (schematic diagram)

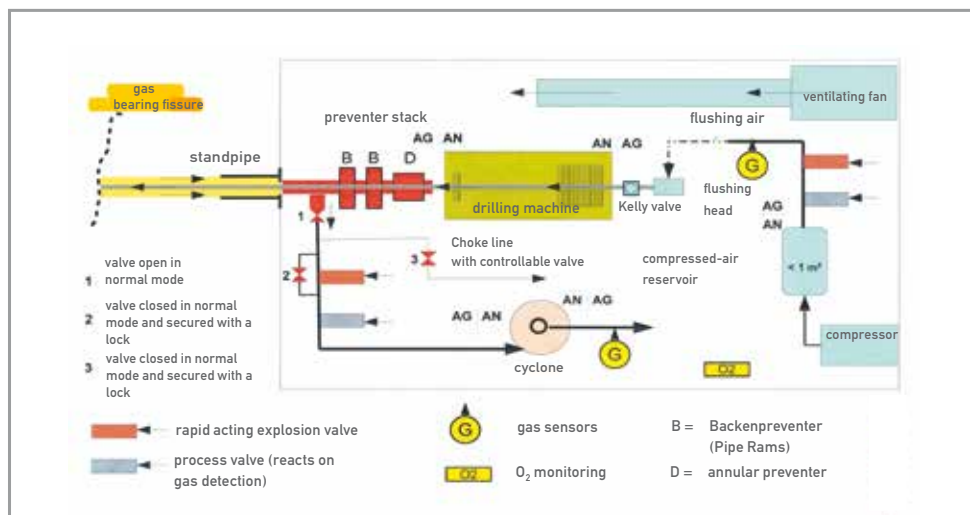

Preventer stack HQ Asse overview drawing: Single components of the construction site facility and their arrangement with each other (schematic)

Test phase 2:

- 574 m-level 105 bar (30 min)
- 700 m-level 130 bar (30 min)

The leak test is considered passed if at the end of both test phases, the pressure in the loaded standpipe is within 1 % of the original pressure.

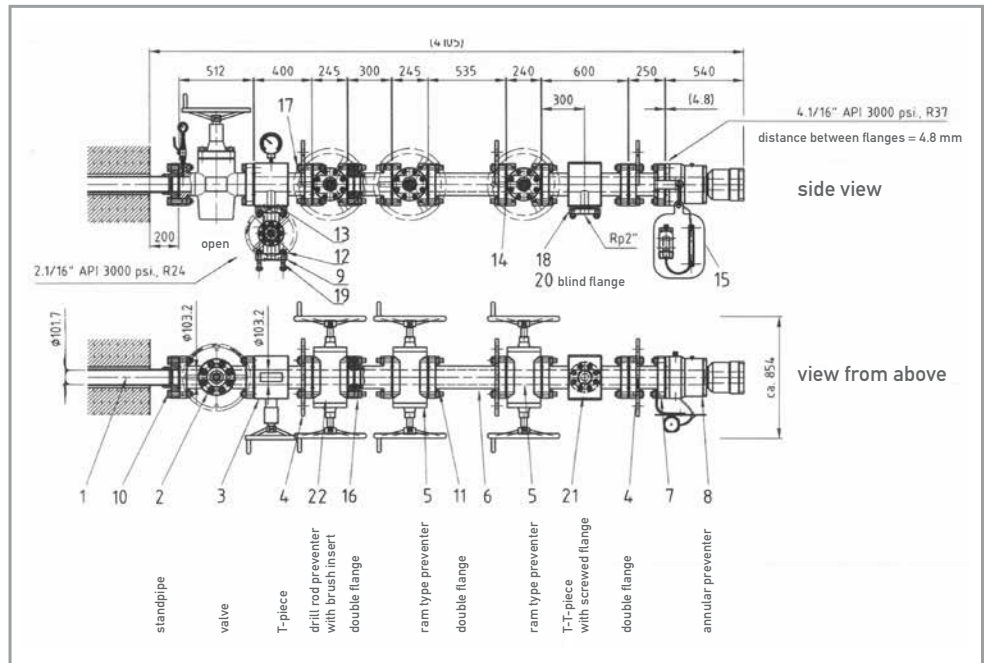

## Gas and Explosion Protection

The equipment required to manage gas and explosion hazards are provided by the client. This equipment includes gas

measurement instruments (sensors with analysis and control unit), rapid-acting explosion prevention valves, process valves and pipes.



## Borehole Measurements

Several different methods of geophysical borehole measurement are to be employed after the core drilling has been completed. If required, Asse GmbH can also request that measurements are taken before a borehole has reached its final depth.

The following measurements are to be carried out:

- Borehole path measurements, intermediate measurements, and final position measurements
- Electromagnetic radar measurements (EMR)
- Caliper measurements

## Summary and outlook

Once all of the boreholes in the saliniferous Asse syncline have been drilled and analysed, the data obtained will help ensure that the retrieval of the radioactive material can be carried out in a reliable and environmentally safe manner.

The Asse II Mine project has provided the opportunity for THYSEN SCHACHTBAU to be recognized for its expertise as a drilling contractor, particularly given the successful completion of the near horizontal core drillings which are over 350 m in length.

Mario Widmar  
Tilo Jautze





Safety fitting preventer stack

## Safety is paramount in targeted exploration of mineral deposits

**With the recent downturn in the commodities markets, many raw material companies are exploring new extraction sites in preparation for the next increase in demand. The horizontal and vertical drilling of preventer-equipped exploration boreholes has provided the Shaft Sinking and Drilling Division of THYSSEN SCHACHTBAU GMBH with an opportunity to showcase its expertise in the exploratory drilling sector.**

### ■ The Safety aspects of exploration drilling

The exploratory drilling industry employs a series of measures to protect the integrity of the mine, underground workers, property and equipment from the effects of a sudden discharge of gas and fluids which can occur when drilling underground boreholes. A key safety measure employed when the exploration site is being prepared, is to install a standpipe of at least 10 m in length in order to create a connection between the rock and the control equipment, known as a “preventer stack”. The preventer system consists of the safety valve (Kelly), the T-piece, the ram preventer and the main seal. The annular preventer is typically not considered to be part of the safety system.

The components of the preventer stack are designed to perform a number of specific functions. The safety valve is designed to protect the borehole from the ejection of fluids and/or gases. The T-piece is normally used to introduce the required amount of flushing mud into the annulus. In the event of an emergency the T-piece can also be used to inject sealant, to monitor pressure levels and to drain fluids in a controlled manner. If a dangerous situation arises, the annulus and drill string can be shut off by means of the ram preventer, both of which would still be in the borehole. If the drill string is outside the preventer, the open borehole can be closed using the main seal.

While drilling, the annular preventer seals the annulus between the drill string, the opened main seal and the open ram preventers. Proper installation of the standpipe and safety set will prevent leaks during the injection of drilling fluids, regardless of whether the drill string is in place or not. Proper installation of the standpipe is verified with a pressure test equivalent to 1.5 times the hydrostatic pressure calculated as a function of the vertical depth of the drilling site.

TS drilling teams receive specialized training by attending courses such as the “Basic Principles of Borehole Control” from officially recognized colleges, including the Celle School of Drilling. As a result of this training, which covers the proper deployment and use of safety equipment, TS drilling teams can respond quickly and effectively to any emergency. Underground exploration involves drilling a number of horizontal holes in various directions from an underground drilling site, typically with a maximum length of 2,000 m. By adopting an undulating course and/or by drilling deviation holes it is generally possible for the mineral resource, its quality and in some cases the actual boundaries of the deposits to be established at predetermined intervals.

### ■ Specialized equipment used by TS

The equipment used for horizontal and vertical exploration drilling consists of a universal drilling rig with electro-hydraulic drive (Hütte type HBR 201) and an electrically driven triplex mud pump. All equipment components are designed with explosion protection and are certified according to ATEX requirements. The modified drilling rig gives TS a high degree of flexibility and allows them to cover a broad spectrum of mineral exploration assignments, all without sacrificing protection from explosions in the event of a gas outburst.

In addition to conventional wireline coring, the Shaft Sinking and Drilling Division of TS also utilizes a saturated brine solution counter-flush coring technique. This highly effective and cost efficient core drilling method has already proven very effective under the conditions encountered in horizontal exploration drilling. Unlike the wireline coring method, the drill core can be continuously recovered from the drill rod due to the reversed mud circulation, or counter-flush. The annulus between the drill rod and the walls of the borehole is sealed by the preventer stack, which allows the drilling fluid to be counter-flushed through the annulus. The preventer stack locking system also acts as a borehole safety device by preventing any ingress of gas or brine from the surrounding rock.



### ■ Technische Daten der Bohranlage

Drilling rig data	HBR 201
Designation	HBR 201
Length [mm]	6300
Width [mm]	1500
Height [mm]	1900
Max. torque (KDK rated) [Nm]	1217
Max. speed of rotation (KDK rated) [min <sup>-1</sup> ]	350
Max. thrust at drill feed [kN]	200
Max. retraction force at drill feed [kN]	200
Max. feed rate [m/min]	13
Max. retraction speed [m/min]	17
Power input at drive unit [kW]	132
Supply voltage at drive unit [V]	500

### ■ Conclusions

TS has extensive experience in drilling boreholes on surface and underground in the mining industry. TS has developed and continues to develop specialized technical borehole drilling solutions to ensure project success.

*Frank Hansper  
Mario Widmar  
Tilo Jautze*





Raise boring site

# Building the world's steepest funicular

**A new funicular railway is being built to replace the Stoosbahn, a now outdated rack-and-pinion system that travels from Switzerland's Muotatal valley to the plateau community of Stoos. Once completed, the new system will significantly improve the area's tourist infrastructure, carrying both goods and passengers over difficult terrain. THYSSEN SCHACHTBAU GMBH was awarded the contract for the construction of the pilot holes for the two tunnel sections.**

## ■ Project Summary

In order to excavate the full tunnel profile, two tunnel sections will be excavated along a gradient of  $47.73^\circ$ , each of which will require its own pilot hole. The pilot holes will allow the broken rock material produced during the full tunnel excavation process to be removed from the work area using gravity. Once the pilot hole is completed, the tunnel excavation process will involve simply dumping blasted rock material down the hole, allowing for fast, efficient materials handling.

The pilot holes required for the two tunnels are 1.80 m diameter for the 99 m long Ober Zingeli section, and 1.40 m diameter for the 259 m long Zingelifluth section. Both pilot holes are to be created using raise boring methods. To begin pilot hole development, the raise bore is set up at the top of each tunnel section and a 9 7/8 inch (25.083 cm) pilot hole is drilled into a predetermined segment of the tunnel profile using directional drilling technology. When the pilot hole breaks through into the lower level, the directional drilling unit and roller bit are removed and the drill string remains in the hole. At this point a 1.8 m long, 1.4 m diameter reamer is attached to the drill string. Once the reamer is attached, the pilot hole is then reamed to its final diameter, starting from the bottom of the hole and working towards the top.

## ■ Description of work

Following the break-through in July 2013, the team of TS began to prepare all of the equipment and hardware that would be required for the project. In September 2014, the upper and lower stations had been installed, the rock faces



and slopes had been properly stabilised and TS received the go ahead on the project.

One of the team's biggest challenges involved setting up the raise bore and the equipment on the edge of a 900 m cliff, in an area measuring just 150 m<sup>2</sup>. Each piece of equipment, including the raise bore and the material containers, could only be brought in and installed by cable-car or helicopter. The materials handling, the setup and the removal of the directional drilling plant were all completed using the cable-car installation.

Drilling began at the longer and lower Zingelifluth tunnel first. This portion of the drilling involved increased outlay for the pilot hole, the directional drilling technology and for the flushing system. If possible, this portion of the drilling was to be completed before the onset of winter.

The pilot hole drilling proved to be an extremely difficult task and a number of complete losses of circulation occurred, which lead to costly borehole cementation work. In spite of significant mud losses, the pilot hole broke through at 260.90 m on July 14th 2015. Because of the loss of circulation, the final 50 m of the hole were drilled using the relatively rigid raise-boring rod and without a directional drilling unit. In spite of this, the deviation from the specified gradient was still low, at approximately 1.00 m. This amount of deviation was in line with the requirements as it was still on target in the tunnel cross section.

After a somewhat protracted but ultimately successful pilot hole operation it was then necessary to provide a secure access point for the attachment of the reamer head. This called for rock-face stabilisation measures and the construction of a concrete installation pad. The reamer was then manoeuvred into position and attached to the drill string using the material cable-car.



A great challenge: The installation of the raisebore machine in the rock face

The subsequent reaming phase was completed without any significant setbacks. After 17 working days, break-through was achieved and work could begin at the drilling site for the Ober Zingeli upper tunnel section. Relocating the drilling equipment was carried out exclusively with the materials cable-car. Drilling of the pilot hole and the subsequent reaming to 1.80 m diameter all went smoothly in the 99 m long Ober Zingeli section; the entire process was completed after just 23 days.

## ■ Conclusions

The new funicular railway at Stoos continues to pose technical challenges for the engineering team involved in both the tunnel extension work and the installation of the tunnel support lining. The preparatory work at the drilling site and the raise boring operation provided the TS team with an opportunity to display their mountaineering abilities as they travelled to the worksite, where difficult weather conditions made routine tasks seem arduous. Both sections of the raise were successfully completed as a result of the effort and commitment displayed by TS personnel. Their performance played a major role in the team's success on this unprecedented funicular railway project.

*Tilo Jautze  
Joachim Ravenstein*

### Reference:

- (1) <http://www.stoos-muotatal.ch>;
- (2) [seilbahn.net](http://seilbahn.net)





## THYSSEN SCHACHTBAU GMBH raise boring team succeeds in developing challenging ventilation shaft in Macedonia

After successfully completing numerous raise boring projects at the SASA lead-zinc mine, THYSSEN SCHACHTBAU GMBH was selected to develop a particularly challenging ventilation shaft for the project. The task involved creating a 300 m long borehole at an angle of 37° from the vertical, which was a considerable technical accomplishment for both the drilling crew and for the equipment.

### ■ On-site operations 2013 - 2015

After two years of raise boring operations at the SASA lead-zinc mine, which is near the town of Makedonska Kamenica in eastern Macedonia, the raise boring programme was completed in mid-2015. The project involved developing 16 inclined raises in areas throughout the mine. All of the raises are 1.8 m in diameter with lengths varying between 70 and 300 m. The raises were developed to be used as ore passes and ventilation raises. The entire operation was carried out by a ten person drilling crew operating a Wirth HG 160/II raise bore.

### ■ Ventilation shaft poses a difficult challenge

The ventilation shaft that was completed in early January 2015 turned out to be the most challenging raise for the drilling team. This ventilation raise, which was 288 m in depth and angled at 37° from the vertical, had its start point in an abandoned part of the mine, several metres above the current workings.

The entire raise bore was transported from the active workings to the surface up a ramp. All of the other raise boring equipment had to be transported along a winding mountain road to reach the old mine workings. By moving equipment along these two different routes, the drilling team

was able to transport approximately 140 t of equipment to the new drill site.

Once all of the equipment was brought to the work area, the raise bore was re-assembled and set up in an excavation that measured 8 m high by 6 m wide. The excavation was connected to a 1,200 m-long crosscut with a cross sectional area of just 16 m<sup>2</sup>.

After 18 days of drilling, the pilot hole was completed with the required level of accuracy, despite numerous challenges from inconsistent geological conditions. The increased outlay required for the project, which included a longer drilling time, was primarily the result of measures taken to prevent hole deviation; the drill string was removed from the hole several times to adjust the stabilisers.

Further delays also arose during the reaming phase of the project. After just a few metres of reaming, the reamer was returned to the bottom of the hole so that worn roller-cutters and roller-cutter saddles could be replaced. Highly abrasive rock in the bottom section of the hole had caused an unexpectedly high amount of tool wear. To make matters worse, the increased tractive effort and considerable torque required to overcome the slope and depth of this particular hole meant that the Wirth HG 160/II raise bore frequently operated at the limits of its capacity.

### ■ Summary and outlook

This extremely challenging raise boring assignment was completed safely and to the client's complete satisfaction despite the many obstacles that had to be overcome. The success of this project has provided THYSSEN SCHACHTBAU with the platform for additional work with the client, which is currently in discussion.

*Tamara Portugaller  
Stefan Schichtel*

# Raise boring in Austria: GKI – ,the fastest raise in the world!'

**This 100 m-long raise bore hole, which was commissioned by the GKI-Ried/Prutz joint venture, was completed in the summer of 2015 in record-breaking time. The success of the project, which was executed by THYSSEN SCHACHTBAUGMBH's Austrian subsidiary, can be attributed to exceptional logistics and a strong team spirit.**

## ■ The Project: Joint Venture Power Plant Inn

The Joint Venture Power Plant Inn is a unique, cross-border run-of-river power station located on the border between Switzerland and Austria. The plant's headrace tunnel passes through seven communities along a north-east to south-west axis, commencing at the Swiss municipality of Valsot in the South-West and running all the way to the Kauner valley in the Austrian Tyrol. The three main components of the Power Plant Inn are the weir system, the headrace tunnel and the powerhouse.

## ■ The fastest raise bore in the world

The blind shaft, which is 100 m in depth and 14 m in diameter, forms part of the headrace tunnel and serves as a surge chamber. The shaft was sunk using conventional drill and blast methods around a pilot hole. The 1.8 m diameter vertical borehole was developed as a means to remove the blasted rock from the shaft bottom and was completed by TS in the summer of 2015.

The transport arrangements for the boring rig were a true logistical feat; the raise bore and all of the associated equipment and materials were procured from a number of different countries and had to be transported to the worksite in the Kauner valley. From here, the drilling plant and equipment was transferred to seven small pickup trucks, which then had to travel up a mountain road to reach the tunnel entrance, at an altitude of more than 1,000 m. In just one day everything was delivered to the site, the raise bore was set up and the surface location was fully surveyed.

On working day three the drilling of the pilot hole commenced and continued on a 24 hour-a-day basis. Two days later, the five person drilling team completed the 100 m deep pilot hole. With the completion of the pilot hole, the 1.8 m reamer was attached and began the reaming operation, which was completed in five days.

The raise bore hole for the Joint Venture Power Plant Inn was completed in just eleven days. It is no wonder that the TS team that was responsible for this project could claim proudly, with a twinkle in their eyes, that this was ',the fastest raise in the world!'

*Tamara Portugaller  
Stefan Schichtel*

Layout of the Joint Venture Power Plant Inn (source: GKI)



Successful breakthrough of the pilot hole in record time





# The changing face of the Engineering Office related to the globalisation

**The continuing growth in international business at THYSSEN SCHACHTBAU GMBH has imposed all manner of new challenges for the company's Engineering Office "Thyssen Schachtbau Engineering" (TSE).**

## ■ Major projects in Norilsk and further contracts in Russia

The WS-10 and SKS-1 shaft sinking projects in Norilsk, which provide for the construction of two 2,000 m-deep shafts with an internal diameter of 9 m, have heralded-in a new era and have, for the first time, involved the company in the planning of two complete mine installations outside the European zone. In addition to the sinking equipment the contract also includes the permanent winding gear, the shaft guide fittings and the surface buildings and installations. The latter will comprise the 110 kV power supply plant, the winder hall, storage buildings and of course the shaft headgear itself, which is to be constructed as an enclosed tower that will serve both the initial sinking project and the permanent winding operations.

The work of the planning team was complicated by the fact that the Norilsk region suffers from extreme weather conditions. As winter temperatures can fall as low as minus 50 °C the project called for the use of fine-grained structural steel with a high impact toughness at low temperatures. The permafrost also meant that all the buildings would have to be set on bored piles, as in summer the upper layers thaw out and could cause the foundations to be washed away.

A further challenge arose when arranging for the steelwork to be shipped all the way to Norilsk, as the transport logistics all had to be coordinated with the steel manufacturers. Some of the steel components for the two mine installations were made in Germany and for this reason all the individual parts and

assemblies had to be clearly marked and recorded in dispatch lists. As the components were too large for standard containers special oversized shipping crates had to be built from wood. Some several thousand tonnes of steel were produced in Germany for the two new mines. This material all had to be packed up and shipped out to the site in Norilsk.

After some minor teething problems the two shafts (WS-10 and SKS-1) had reached a depth of 1,700 m and 1,300 m respectively by the month of October 2016. When the sinking phase has concluded the installations will be converted for permanent winding operations. Further planning work will be required for this transition, including for example the construction of the shaft conveyances and skips. The entire sinking plant will also have to be dismantled and the new head frame erected.

In addition to the planning and design work for the mines at Norilsk the company has also planned and put into operation a freeze plant for three deep-level freeze shafts, each requiring ground freeze sections 830 m in depth, for the Gremjatschinskij mine. The Engineering Office and the planning section are working together with colleagues from TS to supervise the freeze build on site, which includes data acquisition and analysis and a numerical modelling system whose purpose is to control, monitor and optimise the development of the freeze wall.

In early 2016 the ongoing planning remit was expanded by a planning commission for another mine shaft in Russia. This contract was linked to the SKRU-2 mine in the Perm region. This installation also requires two new shafts to be sunk to a final depth of about 450 m. The ground freeze method is again to be employed, whereby the Engineering Office has been responsible for the freeze-hole operations and has worked alongside TSE to plan and design the ground freeze plant.



Diagrammatic overview of all the buildings and facilities that will form part of the WS-10 mine complex

Special containers being held at our steel subcontracting firm



The planning operation for the structural steelwork needed for the new mine was also complicated by the stipulation that the steel materials had to be manufactured in Russia. For the designers and structural engineers this meant, for example, grappling with the standard profile geometry of Russian-made beams and girders.

### ■ Major Project Semmering Base Tunnel in Austria

While executing the shaft sinking contracts in Russia the Engineering Office will also be planning a further two shafts that will be part of construction section 1.1 for the Semmering Base Tunnel in Austria. This project is being carried out by a consortium comprising partners Hochtief Infrastructure Austria, Implenia Austria and TS. The main challenge facing this group is to incorporate the interdisciplinary concepts of all the project partners into the planning process and to produce optimised technical solutions that can then be implemented on site.

### ■ Planning for the permanent waste repository Konrad in Germany

On the home front the Konrad permanent waste repository is another major construction site that requires ongoing planning input from the Engineering Office as part of the operation to prepare and refit the support system for Konrad number 1 and number 2 shafts and to create infrastructure areas below ground.

### ■ Further Contracts

As well as the contracts cited above the order books also include a number of pure planning assignments, mainly engineering design studies. A major planning contract is currently being executed for Asse number 5 shaft as part of a consortium venture with partners DMT and K-UTEC. The design work required here ranges from initial data collection and a comparison of variants through to the preparation of approval plans.

A number of smaller projects are also being handled, one interesting example being the design and production of working platforms for the shaft conveyances at the esco-owned Borth salt mine. Figure 3 depicts the moveable platforms, complete with overhead protection and slot-in railings, as fitted to the main conveyance in Borth number 2 shaft. The many moving elements involved show that even small engineering contracts can entail an extensive amount of planning work.

In order to carry out these various major projects the Engineering Office has appointed project managers for both the mechanical and the electrical installations.

The project managers will be responsible for coordinating all the accumulating planning processes, cooperating with external engineering firms and obtaining the necessary permits and approvals as issued by the various mining authorities and regulatory bodies. Engineers and designers from a wide variety of technical fields will be responsible for preparing the concept designs and drawing up the final plans for the shaft construction projects.

Processing the volume of orders coming out of Russia naturally meant increasing the manpower resources available in the Engineering Office, where nearly half of all the staff are now native Russian speakers.

The components for these projects were designed and calculated using the latest 3D CAD and structural analysis software. 3D modelling techniques in particular play a key role when it comes to preventing errors and deficiencies in the subsequent manufacturing process. The staff at TS are regularly trained to use 3D software in ways that will achieve the optimum results. Globalisation has not only changed the scope of the planning work but has also transformed the actual workspace in the Engineering Office. The late 1990s marked the end of the drawing board and the arrival of the first EDP workstations with their bulky, thick-screen monitors and maximum 21" screen size. Today the designers work on several flat-screen monitors at once, the screen size can be as much as 32" and the staff have access to all the benefits of the latest technologies, interfaces and efficient networking systems.

As well as undertaking general contract assignments the Engineering Office is also involved in standardisation work for the mining industry. The original mining standards body, the Bochum-based mining standards committee FABERG, was disbanded at the end of 2015 and all standardisation work for the mining industry is now undertaken by the Beuth Standards Institute in Berlin.

The Engineering Office is also involved in this process through its representation on different standardisation committees. At the end of 2015, for example, the committee responsible completed its revision of mining standard DIN 21500 'Shaft sinking in mining - design and dimensioning', while DIN 4118 'Head frames and winding towers for mines' is currently in the process of being revised.

At international level ISO standards are also being drawn up for head frames, working stages and platforms, shaft conveyances and guide fittings. The Engineering Office is also participating in this work and this means that German know-how is being put to good use in the drafting of ISO standards.

*Till Kaufmann  
Rainer Lietz-Nagel*



# Taking the next step towards implementation



Preventer stack for the underground exploratory holes for the planning of the shaft bottom at Asse 5

## ■ Background

As has been mentioned several times in the two previous issues of the THYSSEN MINING Report, the THYSSEN SCHACHTBAU GMBH has been engaged in various operations at the ASSE 5 shaft in conjunction with JV partners Deutsche Montan Technologie (DMT), Essen, and K-UTEC AG Salt Technologies, Sondershausen. In 2011 this joint venture was contracted by the German Federal Office for Radiation Protection (BfS), Salzgitter, to draw up plans for a new shaft at the ASSE underground waste repository in the Wolfenbüttel district of Remlingen.

ASSE number 5 shaft is to be used for the recovery of the radioactive material that was stored below ground at Asse mine and the new installation must at the same time meet the key framework conditions that have been laid down in respect of ventilation, manwinding and material transport. The remit

In 2014 the JV partners commenced work by drawing up a location-neutral variant comparison that took account of the various structural criteria underlying the three shaft-construction phases, namely sinking, preparatory work and waste recovery. This variant comparison took the following aspects into account:

- shaft sinking methodology:  
e.g. conventional drilling and firing or mechanical shaft milling machine and excavator
- possible concepts for strata reinforcement during the sinking phase:  
e.g. creation of a freeze wall (freeze shaft method) or – if necessary – systematic strata injection
- shaft support options:  
e.g. sliding shaft, steel ring or concrete support system
- possible winding systems:  
e.g. winding tower, strut frame or tower frame
- and also considered a range of additional features, up to and including the surface plant and facilities that would be needed.

The aim of this comparison was to propose a number of most likely options. The variants preferred by the BfS would then be examined on the basis of assessment criteria such as reliability and fitness for purpose, while also taking into account factors such as cost efficiency and radiological safety.

### ■ Ongoing progress

This planning exercise now incorporated the evolving knowledge being acquired from the Remlingen 15 (R 15) exploratory drilling that concluded in mid-2014 as well as from the various investigations and tests conducted both during and after the drilling operation.

A comparator was then to be developed from the early site-neutral study work that would factor-in as far as possible the site-specific circumstances prevailing at the location chosen for the new shaft.

The need for such an approach had already been demonstrated when some fairly significant deviations from the originally assumed boundary conditions were encountered in analysing the results obtained from R 15. This mainly related to the structural geology and formation of the Asse anticline.

However these new findings were not expected to affect the situation to the extent of forcing an abandonment of the plan to construct a new shaft south-east of the K513 county road. The expert teams involved were generally in agreement that as things stood there were no contributing factors likely to affect the construction of the new shaft at the planned site; however it should be borne in mind that the shaft collaring point might have to be moved some small distance away.

As regards the positioning and construction of the new underground excavations that would be an essential feature of the recovery operation, it was imperative that further exploration measures be initiated, and the results evaluated, over and above the operations currently under way in this area, i.e. the horizontal exploration holes that TS is drilling for the client Asse-GmbH on the 574 and 700 metre-levels.

These additional measures should dispel any uncertainties still surrounding the overall design of the project, thereby providing a reliable body of information for the subsequent conceptual and detailed design stages that should ultimately result in official authorisation being granted for the sinking of the new shaft.

### ■ Own agenda

At this point it should be mentioned that as progress continues on the new ASSE 5 shaft it will also be possible in 2016 to resume the planning work required for another BfS commission, namely the existing ASSE 2 shaft project that was suspended back in 2012. However this will involve adapting to a new set of parameters, particularly with regard to ventilation, manwinding and materials transport.

### ■ Outlook

Pooling the expertise acquired from these two planning assignments will result in a waste recovery plan for Asse mine that is safe, reliable and fit for purpose. This will allow a start to be made on this globally unparalleled project at some point in the foreseeable future - a development that will be welcomed by all parties.

*Thomas Jank  
Markus Westermeyer*



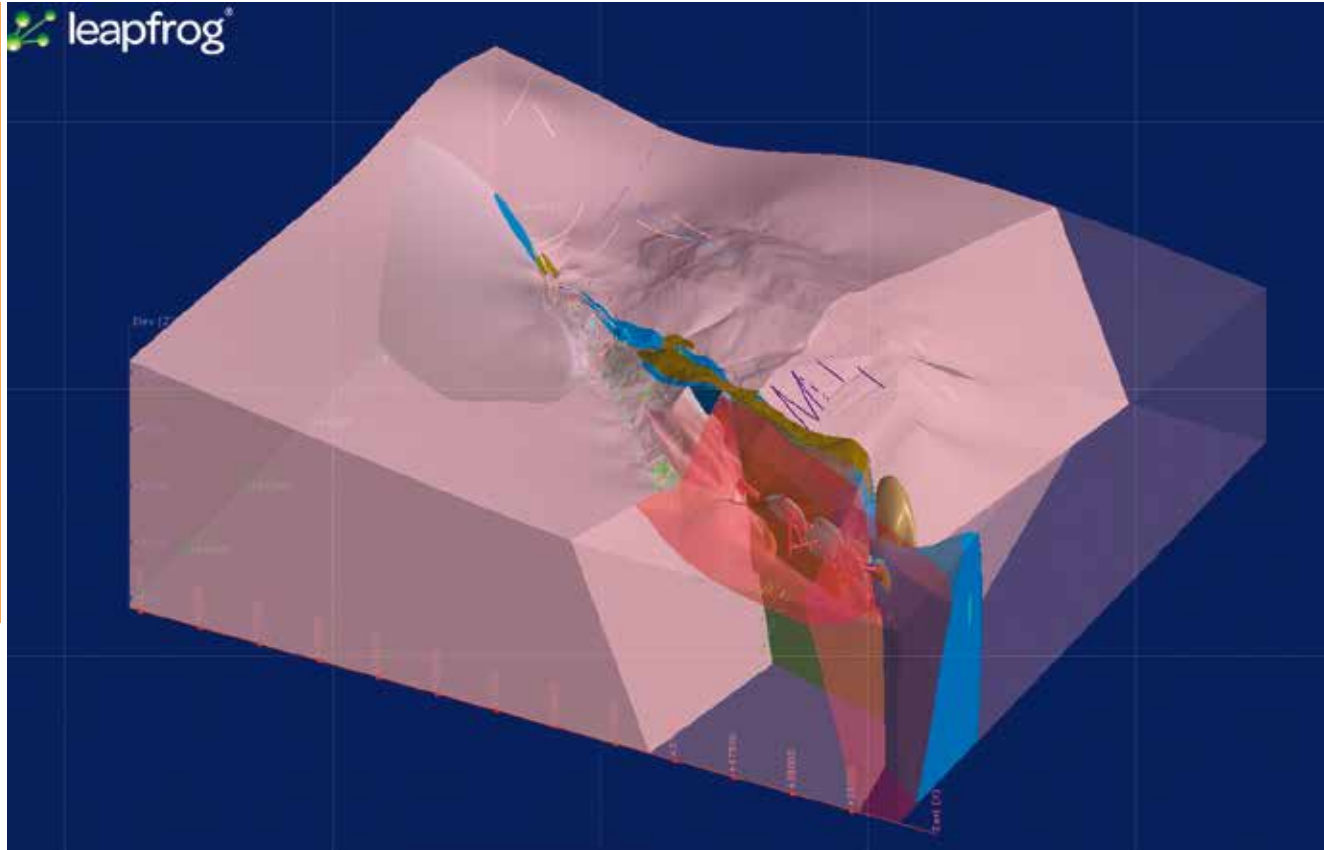

Leapfrog geological model of the Russian gold project

# Mining Plus in Australia marks 10 years of success

Geotechnical and mining consulting company Mining Plus has become a significant international player since its founding in Perth in 2006. Combining technical expertise with practical experience the firm is well placed for sustainable growth and has a proven track record in delivering innovative and practical solutions. Core services now range from project conception to feasibility study work, project delivery, commissioning and mine closure, as illustrated by the following five case studies.

## ■ Case study 1 – Russian Gold Mine

Mining Plus produced a Mineral Resource Estimate to enable transition from hand-held to mechanised mining. The mineralisation in question features numerous quartz veins and shearing and faulting have created quartz-filled zones forming numerous consistent lodes over a large area. The work involved:

- A 3D geological model, the first in the 19-year history of the mine.

- Review of drillhole data collection and storage for compliance with industry standards
- Mineral Resource Estimate of gold and silver content.

## ■ Case study 2 – Pilgangoora Tantalum-Lithium Project

Mining Plus was commissioned by Pilbara Minerals to complete a Pre-Feasibility Study (PFS) on the Pilgangoora Tantalum-Lithium project (Pilbara Minerals). The PFS was based on an updated geological model and resource estimation completed in January 2016 and consisted of:

- Conversion to a mining block model
- Development of mine planning criteria
- Numerous mine shape optimiser (MSO) runs and open pit optimisation runs
- Mine design and scheduling
- Environmental considerations
- Cost and revenue modelling (mine establishment, operating costs, explosives, plant maintenance, ore handling and crushing, topsoil management, load and

haul costs, drill and blast costs, and infrastructure requirements)

- JORC (2012) Ore Reserve Reporting
- Liaising with external contractors.

Two pits were optimised and designed in Surpac. The five stages were then modified to thirteen in order to streamline the mining process and optimise the schedule. The final pit estimated the probable Ore Reserve to be 29.5 million tonnes.

### ■ Case study 3 – African Copper Mine

Since 2014 Mining Plus has performed three mining studies to determine the economics of this extensive mining project. This work included pre-feasibility evaluations, truck-conveyor-shaft comparisons, open-pit versus underground trade-off study, cost modelling etc. Drilling in 2014 and 2015 identified 35.9 million tonnes of additional Inferred material averaging 1.86 % Cu along with continued resource expansion potential. The study ultimately confirmed that an increase in the mine production rate from 3.65 Mtpa to 6.1 Mtpa will increase the project NPV. It also rejected the use of a shaft haulage system. The total cost was estimated at \$2,300 M, including \$220 M of pre-production capital costs. Long Hole Open Stopping was selected as the most effective mining method. The mine will have a strike length in excess of 4km. Project Life of Mine is estimated at 18 years, with extensions to this highly likely. The project will create some 1000 jobs at peak production. A specialised deep mining contractor will be used for the first 3 years with a gradual transition to 100 % owner-operator.

### ■ Case study 4 – El Compas

This gold and silver mining project is owned by Canarc Resources Corporation in Zacatecas (Mexico). Mining Plus completed a Preliminary Economic Assessment comprising technical visit, preliminary mining method selection, mine design and cost estimation and revenue model. Highlights: annual production of 18,000 ounces AuEq, 7.3 year lifespan at

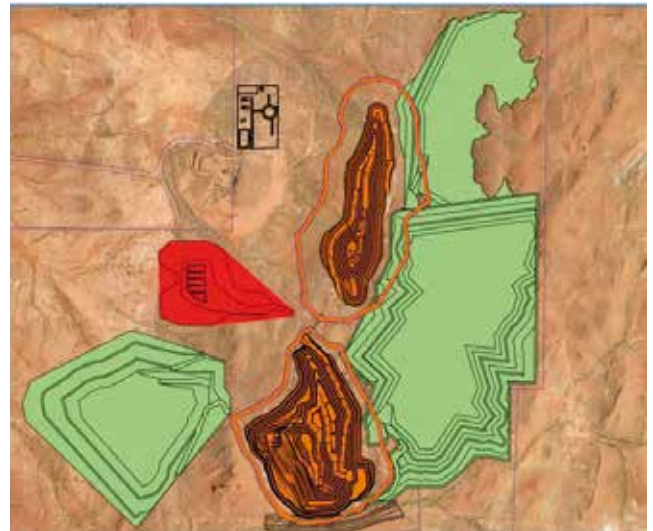

Pilgangoora pits and mine layout designs

450 tonnes a day using a local mining contractor to produce 126,000 net payable AuEq ounces. The material is to be trucked 20 km to the La Plata process plant for crushing, grinding and flotation followed by leaching of the concentrate. The Life of Mine payable production will total 115,000 ounces of gold and 886,000 ounces of silver for a total of 126,000 ounces Aueq.

### ■ Case study 5 – Ollachea Mine technical improvements (Minera IRL, Ollachea Project)

This greenfield underground mining project in the Puno District of Southern Peru is located in an area with a rich history of mining dating back centuries. The Ollachea Feasibility Study completed by Mining Plus indicated that an underground mining operation was economically viable. Mining Plus were commissioned to produce a Feasibility Study level design and schedule using Minera’s updated resource model to maximise gold recovery and project NPV. This included a detailed Geotechnical Analysis based on core logs and other data. Information gathered from the host Ananea Formation during the exploration and development phase

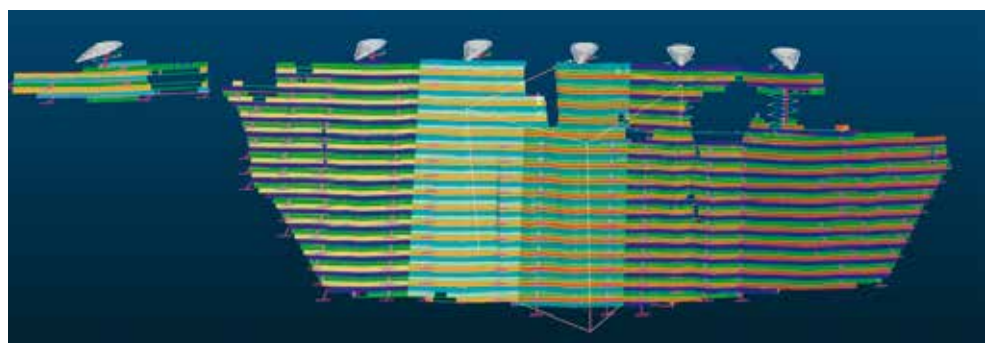

Isometric view of the mine design



was considered the highest confidence data and proved critical for the mine design parameters. The Q system was used to categorize the rock mass and to devise the ground support requirements. Mining Plus ultimately produced a mine design and schedule for Ollachea that included an estimation and reduction of dilution, stope optimization using Datamine™ MSO software, an incremental cut-off grade and an optimised schedule based on multiple mining fronts/levels and prioritizing high grade zones. The study achieved a 17 % increase in project NPV by increasing mineral reserve tonnage (by 3 %) and gold recovery (by 1 %), reducing the production ramp-up period and identifying savings in mobile equipment and elsewhere.

### ■ Conclusions

With the combination of technical know-how and operating experience Mining Plus is given the optimal strategic preparation for a future with sustained economic growths. The company has an excellent reputation when it comes to the development of innovative and practical solutions.

*Brad Evans*



Ollachea Mine in the Puno District of Southern Peru



LIDAR Scanner set up on shaft bottom

## LIDAR scanning Newmont Leeville No. 3 ventilation shaft

In June of 2013, Thyssen Mining Construction of Canada Ltd. (Thyssen Mining) was awarded the Shaft Sinking contract for Newmont's Leeville Ventilation Shaft #3 in Carlin, Nevada. As part of the sinking phase of the project TMCC utilized a Z&F IMAGER® 5010C LIDAR laser scanner to capture HDR images and high resolution point cloud data of the shaft excavation profile as sinking progressed. This data was then processed and used to generate estimated concrete pour volumes and provide design conformance verification as well as provide a record of excavation profiles and geological conditions.

### ■ Geological Mapping

Thyssen Mining Site Engineers processed point cloud data for each 4.6 meter section of excavation and overlaid the HDR imagery onto the resulting 3-D surface rendering to provide the client a 3-D model of the excavation. In addition, a long section of the previous 5

consecutive sections was provided with each report submitted to the client for comparative purposes. These deliverables were combined with logging of the geological

conditions encountered within each excavated interval to give the client a robust picture of geological conditions throughout the shaft profile.

### ■ Design Conformance Verification

The collected data was also used to analyze the excavated sections for any areas that had not been excavated sufficiently to allow the minimum concrete liner thickness specified in the shaft liner design. These areas were then



Typical excavation profile long section with HDR imagery overlay



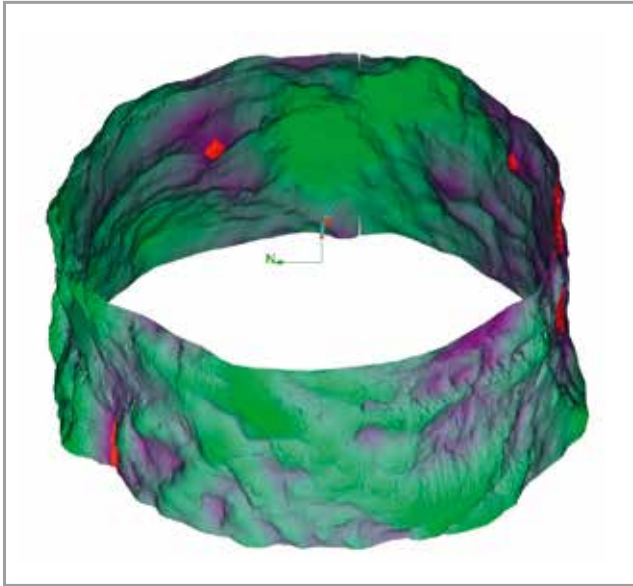

Excavation for pour 107 colored by radial distance from shaft centerline (red areas are less than minimum design)

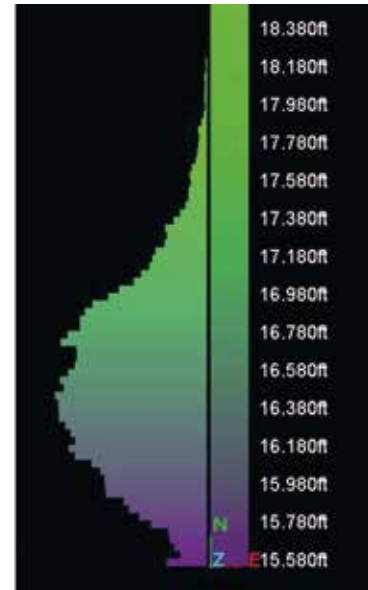

Picture right: Corresponding histogram for shaft pour 107 denoting point distribution by distance from shaft centerline

identified in the field and further removal of in-situ material was completed prior to concrete placement to ensure minimum liner thickness was achieved. Deliverables to the client for this work included: the 3-D excavation surface colored to show areas needing further excavation, a histogram corresponding to the 3-D surface showing the excavation radius from shaft center, and before and after images of each area where remedial excavation was performed. Thus, Thyssen Mining was able to provide the client with verification that each liner section met minimum design criteria.

### Concrete Volume Estimation

In total 107 excavation sections corresponding with 107 separate 4.6 m liner sections were scanned. LIDAR scan data was used to calculate an estimated volume of concrete for each concrete liner pour. The mean variance between

estimated volume and actual concrete volume for these sections was 5%. This estimation allowed Thyssen Mining to coordinate more closely with our concrete and shotcrete supplier, Jetcrete North America, in planning concrete delivery and raw material inventories for the batch plant.

### Minimal Interference with Cycle

In order to minimize the LIDAR scanning operations' impact to the mining cycle scanning was conducted at the end of mucking cycles. This allowed scanning to proceed concurrently with preparations for ground support installation. Scanning of excavated sections was conducted after completion of the muck cycle while the bolting equipment and supplies were being prepared and sent to shaft bottom and the shaft shotcrete sprayer was being lowered to and chaired on the work deck. This arrangement resulted in virtual elimination of interference with the mining cycle as scanning was completed before the shotcrete gear was ready to commence operation.

Area of excavation requiring further material removal



Same area of excavation as above after material removal



Jason Henderson

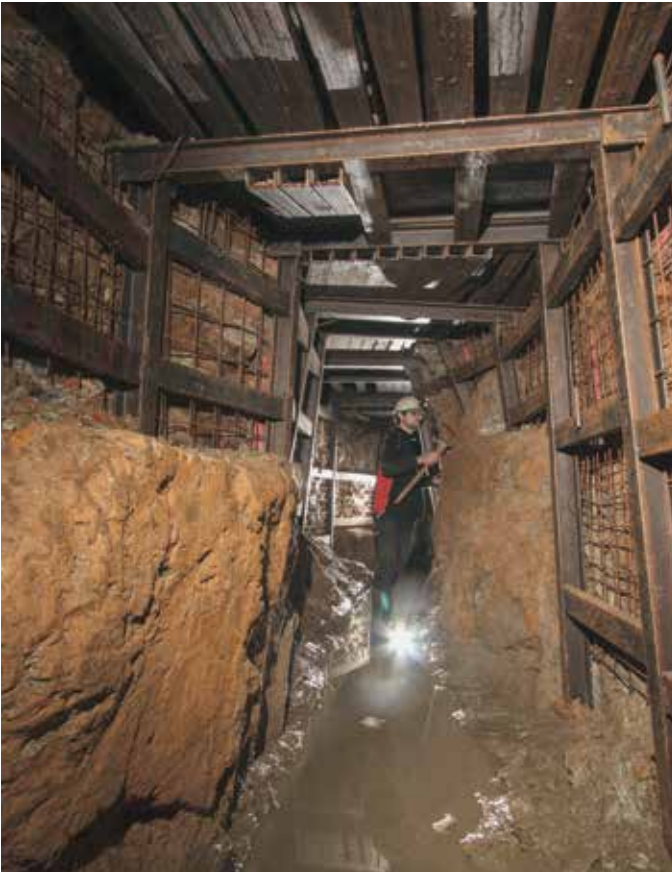

Spiling in the back with a slight lagging of the face



Steel support and shotcrete secured with crosscut in the pumping shaft

## Long-Term solution to mine-water drainage in Breitenbrunn

The community of Breitenbrunn in the Ore Mountains of the Free State of Saxony has repeatedly suffered from serious flooding on Erlaer Street. The flooding typically occurs after periods of persistent rainfall, with the water originating from the former mine sites in the area. These water flows have affected not only Erlaer Street but also the adjacent commercial and residential areas. The acute risk that the flooding posed in terms of public order and safety resulted in the Saxon Upper Mining Authority in Freiberg commissioning mine renovation and restoration works to eliminate the flooding. The Mining Authority, who is responsible for managing hazards related to abandoned mining installations in the Free State of Saxony, awarded TS BAU GMBH with the contract to undertake this operation.

### ■ Preliminary Exploration, Planning and Contract Arrangements

The first step to eliminate the flooding was to analyse the area where it was occurring. The source of the water outflow was identified as the workings of an old and partially unmapped mining area, with most of the flow coming from the Fortuna inclined shaft. The only way to reduce or eliminate the flow of water was to divert it in a controlled manner. Based on the results of the analysis it was decided to use the existing galleries for dewatering, which had historically been used for dewatering the Fortuna workings. The available mine plans identified two suitable tunnels in the abandoned mine workings, namely the Kaltwasser Deep Drift and the Johannes/Schwarzenberg Common Gallery. Connecting the flow of mine water from the Fortuna inclined shaft to these two tunnels would not only significantly reduce or eliminate the inflow into Erlaer Street, it would also establish stable hydraulic conditions for the Breitenbrunn residents with houses along the valley slopes. For these reasons, the plan attracted significant public interest.





Extraordinary pretty and stable drift of the Kaltwasser deep drift

The Chemnitz-based mine planning office TABERG-OST GmbH was commissioned to create the planning documents for a controlled and permanent drainage of mine water from the workings of the Fortuna, Segen Gottes and Kaltwasser mines and from the deep-measures drift in the vicinity of Breitenbrunn. These documents were then used by the Upper Mining Authority of Saxony to issue a call for tenders. After the tenders were reviewed, the bidding consortium 'Restoration of the Breitenbrunn Mining Galleries', comprised of TS BAU GMBH, branch office Jena, and Bergsicherung Sachsen GmbH, was awarded the contract to provide a system for the controlled, long-term drainage of mine waters in and

Skarn deposit near the surface partly wasted with debris



around the community of Breitenbrunn. The project was financed by the European Fund for Regional Development.

### Restoration of the Old Mine Drift

The situation prevailing in the old mine workings was complex; the mining industry of the region is steeped in history (mining started back in the 14th century) and is a tale of repeated interruptions. For this reason the area has not been completely mapped out. In June 2012 work began to survey, clear out and secure the Johannes/Schwarzenberg Common Drift. The first 250 m of tunnel showed no signs of roof collapse or fallen debris; the rock in this section was still stable despite being unsupported. The decision to install an overhead monorail meant that in some sections the side-walls and back had to be slashed using conventional drilling and blasting. Several partial and full cave-ins were then encountered further along the drift. The collapsed areas were secured with steel frame supports and roof lagging, while pressure boxes were installed in the ore extraction cavities. In order to shorten the transport lines, improve the ventilation conditions and create a secondary emergency escape route, the inclined surface shaft and entry to the Johannes drift was cleared out and secured. The rest of the Johannes/Schwarzenberg Common Drift, which went as far as the end of the rehabilitation area at the 820 m mark, was mainly marked by partial and full cave-ins though stable sections of tunnel were also present. At the end of the drift the date '1825' was found inscribed into the tunnel wall along with the measurement '256', which matches the figures recorded in the old mining documents. The operation to clear out and secure the Johannes/Schwarzenberg Drift involved moving a total of 1060 m<sup>3</sup> of rock and debris over a length of 820 m and installing 392 steel frames/roofbars.

In order to survey, clear and secure the Kaltwasser Deep Drift a shallow pit was created near Zinnweg Street that broke through into the drift after 7 m. The clearing operation in the drift was mainly achieved using spiling, while steel frames were used to provide the required support. An overhead monorail system was also used for this work. Some parts of the side-wall and back had to be slashed. Clearing work at the level of the Segen Gottes Shaft combined with a lowering of the backwater level to the floor of the Kaltwasser Deep Drift, eliminated any risk of a sudden inflow of standing water. The Kaltwasser Deep Drift was cleared and secured over a length of 310 m, extending all the way to the Segen Gottes Shaft. A total of 925 m<sup>3</sup> of rock and debris was removed and 317 steel frames/roofbars were installed as part of this operation.



Inclined bored connection with raisebore machine Rhino 2007 DC to connect the Kaltwasser with the Commun drift

The shaft itself was also cleared out at the same time. Mine water (standing water) was encountered at a depth approximately 16 m beneath ground level. A permanent water pumping system was installed as the sinking work advanced. At the 20 m mark drilling and blasting was used in order to advance through the solid rock. When the shaft had been worked to approximately 33 m there was a massive inrush of water down into the mine. This inflow indicated that there was a hydraulic connection at this level to an unknown, water-filled cavity or area of mine workings. An unmapped section of workings was then discovered, as assumed, at 33.5 m. The tunnel debris was cleared out and the main line of the Kaltwasser Deep Drift was then reached after a further 5 m of advancement. At the termination point of the Drift the team found an old extraction chamber. An inclined entry led off from the chamber to an upper horizon approximately 12 m higher up.

In order to connect the mine water flowing from the old and unmapped work area a new opening was made into the apex point of the extraction chamber.

A passage was drilled and blasted through the 3.50 m thick concrete seal of the old containment in order to allow the mine water to drain out. The mine-water level could therefore rise freely and enter the drainage system at the 2.7 m level. The relocation of the mine-water drainage route to the drop-hole at the inclined entry was achieved using an open trench method.

In order to drain the mine water from the level of the Kaltwasser Deep Drift (approximately 684.0 m above sea-level) and into the Johannes/Schwarzenberg Common Drift (approximately 623.0 m above sea-level) a 105 m inclined bored connection was made to connect the two tunnels.



Transport of the raisebore machine Rhino 2007 DC to the site

THYSSEN SCHACHTBAU GMBH completed this work in a single continuous operation using a Rhino 2007 DC raise boring machine to drill a hole with a diameter of 380 mm.

## Conclusions

The project to establish a controlled and long-term mine water drainage system was a complete success. TS BAU has for many years been involved in the rehabilitation and long-term preservation of old shafts and mine workings. The contract to repair and refurbish the Breitenbrunn tunnels was an excellent opportunity for TS BAU to demonstrate its professional competence.

*Olaf Einicke  
Manfred Rohde*



The date and the tunnelshield in the Kaltwasser drift





Halle shaft head-sheave with Halle Neustadt in the background

# Exploration work in shaft Halle for Teutschenthal mine

## History

The Halle shaft, which is the production shaft at the Halle Potash Mine, was sunk between 1908 and 1910 for client "Hallesche Kaliwerke Aktiengesellschaft". In 1987 a stopping was constructed in the shaft in order to prevent sweet water from entering the mine workings. The water that collected above the stopping as the shaft flooded could at the same time be used as a service-water reservoir. In 1993 this stopping was removed and the Halle shaft was renovated. Since then it has served as an upcast ventilation shaft and as a second escape route with an emergency hoist for Teutschenthal mine [GTS 2015].

GTS Grube Teutschenthal Sicherungs GmbH & Co. KG (GTS) operates the mine as an underground stowage facility. The targeted disposal of mineral waste material will serve to fill

Shaft working platform with compressor at pit-bank level



the cavities created by the former potash extraction operations and as a result will help protect the surface from the effects of mining-induced subsidence [GTS Homepage]. These stabilisation measures are now being extended to include the Angersdorf mining claim. The starting point for this operation is to be the Halle shaft, which is now to be explored and, if necessary, renovated before it can perform its new role / to be of use. The Jena branch of TS BAU GMBH was commissioned by GTS to investigate the structural condition of the shaft as a basis for drawing up a shaft renovation plan.

## Shaft working platform

The exploration work was carried out from a single-deck, rope-hauled shaft platform with retractable segments. The segments were fitted with telescoping steel pipes so that the platform could be braced against the shaft walls.

The provision of compressed air and electrical power could only be achieved by means of mobile equipment. The associated diesel motor emissions were directed through flexible aluminium pipes and into the airflow above the roof of the cage. Clearing the shaft platform at the end of each shift proved to be a real logistical challenge. As well as serving as a workplace for the exploration team engaged in the shaft the platform also had to be kept on standby at all times as an emergency hoist for Teutschenthal mine, thereby ensuring that a second escape route was always available. As the Halle shaft was the mine's only upcast ventilation shaft the velocity of the air flowing between the shaft walls and the working platform was extremely high whenever the platform segments



Fixing the depth markers



Preparing to drill the tubing segments

and roof covers were folded out. This situation made life very difficult especially for the surveyor team.

### ■ Exploration work

Surveying assignments had to be carried out before the main exploration phase could begin. As well as taking shaft soundings and convergence measurements the exploration team also attached depth markers to the shaft walls at intervals of two metres.

Most of the exploration remit comprised full-hole respectively core drilling work. The full-hole drilling programme was used to determine the thickness of the shaft lining, to identify the location of cavities and to investigate any fluids present. The core drilling work was aimed at recovering samples for the laboratory, where uniaxial compression tests were to be carried out, for example, in order to determine the strength of the concrete lining.

The investigations conducted in the tubing column focused mainly on the rust build-up and the presence of any cavities and fluids. Before drilling into each tubing segment a threaded hole was cut into the metal and a ball valve was screwed into place. The ball valves could be left open for the perforating drill and in the event of an ingress of water could then be closed again in order to maintain the sealing function of the tubing segments. The drill feed was bolted to the tubing ribs on the shaft wall side and was set up on a jack-leg on the platform side.

The drilled holes were used to determine the remaining thickness of the tubing segments and to take samples of any fluids present. Ultrasound investigations were also carried out by DMT Leipzig and in this way the tubing wall thickness could be assessed at a further 80 sampling points. The steel-concrete reinforced section between levels -266 m and -588 m consisted of cast-in-place concrete reinforced with iron rods up to 20 mm in thickness and a subsequent

layer of shotcrete that was also reinforced below the 400 m level. Full-hole and core drillings were executed at ten exploration horizons in this lining section. The dry core drilling operation undertaken in this same support zone represented something of a technological challenge. Instead of the soldered tooth core bits normally used for such work the team had to resort to special diamond core bits with weld-on teeth. In spite of the very high levels of tool wear incurred the team succeeded in drilling through the reinforcing rods and obtaining drill core samples 50 mm in diameter that could be used for the laboratory investigations. Most of the core drilling work was done using electrically powered equipment with compressed-air flushing. Core drill samples were also taken from certain areas of brickwork where damage was more pronounced, the aim here was to investigate the reason why the masonry lining had suffered more wear and tear in some areas than others. After drilling through the brickwork some three metres of core samples were obtained in each case from the in-situ rock salt.

### ■ Conclusions

After adapting the exploratory drilling operation to cope with the special technological conditions present in the Halle shaft the survey team was able to carry out the exploration programme in full. In all the operation

- installed more than 300 depth markers
- drilled over 140 m of hole and
- recovered more than 30 m of drill core samples.

The Jena branch of TS BAU GMBH went on to complete the contract to the full satisfaction of all concerned, thanks in no small part to the very good working relationship established with the client GTS and the on-site management team and the expert support received from DMT.

*Toni Schmidt  
Olaf Eimicke*





CMAC team



# CMAC-THYSSEN Mining Group: A culture change for the future

Established in Northern Quebec since 1995, in the Abitibi gold belt which extends from Wawa, Ontario to Val-d'Or, Quebec, CMAC-THYSSEN Mining Group is a mining contractor and equipment manufacturer that offers a wide range of fully integrated services. CMAC-THYSSEN can serve its clients throughout the entire mine planning and construction process and is active in 15 countries, with a focus on French-speaking Canada and Africa.

In 2013, despite or perhaps because of the favourable conditions in the mining industry, explosive company growth forced upon CMAC-THYSSEN a cultural change in order to go forward. The management team has committed to a sustainable development approach by focusing on fundamental pillars: Health and Safety Culture, Employee's

potential, Innovation, and Environmental and Social Engagement.

## ■ Health and Safety Culture

CMAC-THYSSEN Mining Group believes that disciplined and effective occupational health and safety management is crucial, since health and safety is an ever-evolving field. With this in mind, the Company's team continually strives for superior health and safety performance.

In January 2014, the Health & Safety Director, supported by the President, submitted a culture audit request to the Quebec Mining Association (APSM). The main goal was to understand the difficulty in achieving our accident frequency targets despite the energy expended in that direction. Sixty-seven people were interviewed to evaluate their perception of health and safety in their work environment. The audit made it possible to identify the perceptions of the workers and managers in health and safety, to chart the overall picture of the culture of health and safety, and to prepare a plan project action on a 1½ year. From these recommendations, the Logical Sequence and the Integrated Bonus System were developed.

Growth Evolution



All meetings, operations and work procedures are executed following a uniform structure and a sequential priority:

- Health and Safety
- Quality of work
- Equipment
- Productivity

Quick questions simplify the miner's day to day sequence of work: "Have I verified that my work place is safe for my partners and myself? Do I have the skills and information needed to perform a safe and quality job? Have I checked the condition of my tools and equipment to perform safe and quality work? Have I applied the sequence? Then production will go easy!" The omnipresence of this sequence in all our actions allows us to exchange specific information and thus establish clear and consistent communication, avoiding potential mishaps.

The Integrated Bonus System is based on safe behaviours and prevention, in order to reduce and control the risks at work, to empower the employees in order to involve, motivate and engage them in their own health and safety and the quality of the work they perform. Based on a pro-active instead of punitive approach, the integrated bonus system aims to eliminate the negatives related to the occurrence, reporting, or the seriousness of a work accident. The system is foremost a communication and collaboration tool in order to allow every hierarchical level to act and take action in a common approach to Health & Safety, in order to reach the set objectives. The innovative aspect of the integrated bonus lies in the fact that it contains not only the fundamental evaluation elements of the job (tasks) and of the collective performance (production), but it also integrates a daily and individual evaluation based on the:

- respect of the Health & Safety rules
- quality of work
- maintenance of the equipment used
- quantity of individual work performed.

### ■ Employee's potential development

Strongly believing that the company's growth is mostly propelled by the employees, CMAC-THYSSEN has developed a continuous training program. Responding to health and safety criteria, this program allows the development of each employee's potential according to his or her own career path.

Pneumatic long-hole drills



PLH - First pneumatic long hole drill buggy, designed in 1995, now renowned worldwide

In January 2016 alone, \$230,000 was invested in training, representing 6% of total payroll.

The creation of this training program has also led to the birth of various partnerships with companies based in the northern Quebec region known worldwide for its many deposits of copper, gold, zinc, nickel and silver. The partnership with Sarliaq Holdings Ltd., a local company based in Rankin Inlet, Nunavut, specializing in human resources development, training, manpower placement, consulting and marketing oriented to the mining industry, resulted in the training and introduction of 80 Inuit to the Nunavut workforce. Two recent creations, Avanta Exploration & Logistics Inc., with Charlie Watt and Christine Nakoolak, and Youdin CMAC-THYSSEN, with Dr. Ted Moses, former Grand Chief of the Cree Nation, allow the companies to offer turnkey mining services as well as the technical and practical training in the various Cree communities. The involvement of local communities is key to CMAC-THYSSEN success in providing underground mining services and gaining social acceptance of mining projects.







Drill handling system (DHS)

After only one year, 35 percent of the work at the Meliadine mine is performed by labour from the First Nations.

Employing over 685 employees, operating in 19 mine sites in Quebec and Nunavut, and presents in 15 countries, CMAC-THYSSEN offers opportunities and individual challenges.

### ■ Innovation

For CMAC-THYSSEN Mining group, innovation and creativity are an integral part of the culture and business philosophy. With the mining sector constantly facing challenges, CMAC-THYSSEN considers research and development essential for improving the mining industry's performance. The first pneumatic long-hole drill buggy, designed in 1995 by CMAC's founder, reveals that constant drive for innovation. Worldwide recognized, the PLH is now operated in 21 countries. Innovation is truly the key to our success and the key to our sustainable growth.

Slashing platform



CMAC-THYSSEN Mining Manufacturer's core criteria for long-hole drilling equipment manufacturing are centred on safe operation, ergonomics and reliability. Three types of long-hole drills are designed and assembled in Val-d'Or:

- pneumatic long-hole drills (PLH)
- hydraulic or electric long-hole drills (LH II)
- mobile long-hole drills (SPLH).

In recent years, CMAC-THYSSEN has developed several new products:

- self-propelled in-the-hole drill (SPITH)
- drill handling system (DHS)
- slashing platform.

### ■ Environmental and Social Engagement

CMAC-THYSSEN Mining Group is committed to being directly involved in environmental management by carrying out projects that improve the environment, and encourages its associates and collaborators to do the same. It does so, first and foremost, by giving priority to site cleanliness, safe equipment and consumables storage, resource use, and responsible waste production, disposal and recovery. CMAC-THYSSEN believes that environmental sustainability will enable Canada to remain globally competitive in the mining industry through trade and investment. Beyond its commitment to preserve the environment, each year, CMAC-THYSSEN actively participates in the development of the region by investing in cultural, community and sports, and other projects that reflect the interests of its employees and communities.

### ■ The Next Challenge

This approach to sustainable development based on health and safety culture, employees' potential, innovation, and environmental and social engagement, will lead CMAC-THYSSEN to the next challenge for the mining contractor: the social acceptability of any and all projects.

*Luc Guimond  
Ghislain Blanchet*

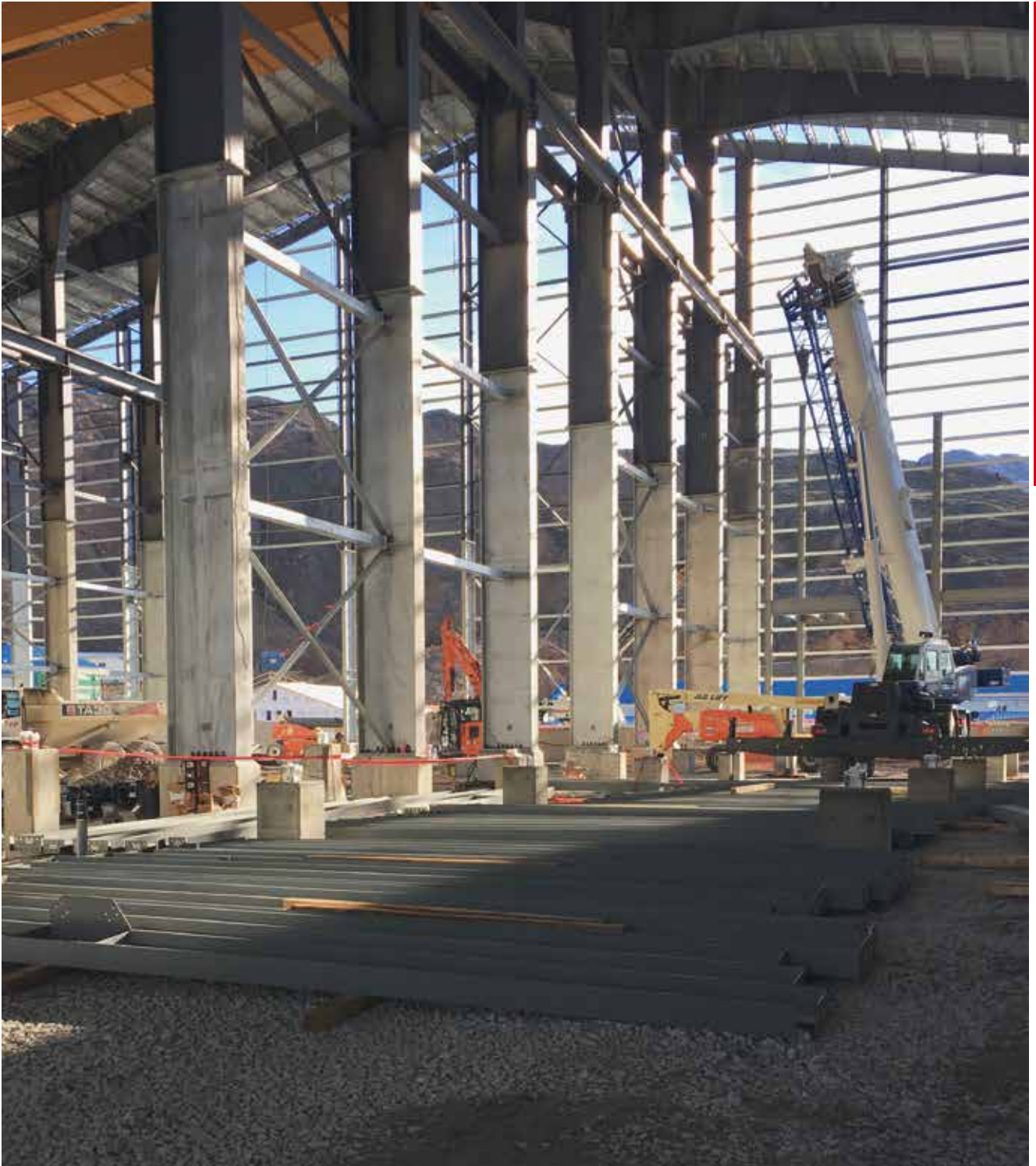

## Thyssen Mining Construction of Canada Ltd. launches Living Sky Industrial Inc.

Installation of a steel construction at the gold mine „Brucejack“ in British Columbia, Canada





Major project „Brucejack“: The only way to get to the mine is to cross a glacier

**Living Sky Industrial Inc. (LSI) is the latest addition to the Thyssen Mining Group of companies.**

**Living Sky Industrial was created to provide Industrial Structure and Building Solutions for the Oil & Gas, Mining, and Power Generation sectors. In addition to providing structural steel erection services, LSI will provide component installation, as well as maintenance and repair services to a variety of industries.**

Living Sky Industrial is currently focusing on industrial construction opportunities in Western Canada, such as the Alberta oil and gas sector. LSI is being supported by Thyssen Mining's head office located in Regina, Saskatchewan. With the assistance of the Technical Services group, the new company recently achieved a major milestone when it received CWB (Canadian Welding Bureau) Certification.

The Canadian Welding Bureau was established to certify companies, inspection organizations, inspectors, and welding consumables through a review and qualification process to ensure that they meet the requirements for a variety of product and safety codes as well as standards. CWB Certification is a requirement for all contractors involved in structural steel erection, piping and component installation, as well as repair servicing and maintenance.

Living Sky Industrial is currently in the process of achieving its TSASK (Technical Safety Authority of Saskatchewan) Certification and an ABSA (Alberta Boilers Safety Association) Certification. These Certifications will allow LSI to install pressure and power piping in the respective provinces.

These certifications will allow LSI to be able to meet a greater range of their client's needs in an industrial project setting.

### ■ First Project

Although LSI was only established in June 2016, it has already secured a major project.

This project is located at the Pretivm Resources Inc. Brucejack Gold Mine. The mine is located in northern British Columbia, Canada; near the Alaskan border. The project entails the installation of over 1,800 tonnes of steel for the mill at the mine.

While the area is remote and will provide significant challenges, LSI's commitment is to meet or exceed our client's expectations by working safely, while delivering a high quality finished product on time and within budget.

*Garry Gill  
Jordan Forbes*

Steel construction with panoramic view



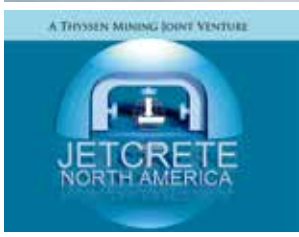

State of the art batch plant at Leeville mine, Nevada

## Jetcrete North America: Filling Gaps in the Shotcrete Industry

**Specializing in, albeit not limited to, underground mining scenarios, Jetcrete North America has successfully extended its Australian parent company's reach into North America, providing quality shotcrete / concrete production and application services with an almost perfect safety record. While Jetcrete North America has been supporting Thyssen Mining throughout its various projects, it also seeks projects independently. When aided by a technological edge over the competition, this endeavor offers much promise in the years to come.**

Jetcrete North America has a large fleet of equipment which is suited to all types of shotcrete or concrete applications. However, we also possess a self-developed remote shotcrete liner technology which enables dry shotcrete application on shaft walls without directly subjecting the employees to the work area.

The entire process is done remotely and at an exceptionally fast pace. The operator controls all aspects of the spraying process from the safety of a control room located outside the hole. No worker interaction inside the hole is required making this an extremely safe process. This sprayer works especially

well with raise bore holes. The spraying unit can easily spray raises ranging in size from 1.5 m to 9 m + in diameter. These holes can be vertical down to 45 degrees in inclination. Also, we have successfully sprayed holes in excess of 450 m in length.

Our portable headframes were designed specifically for use with this spraying system, and are compact enough to be used underground as well as on surface. In extreme cases where a headframe cannot be used this unit is compact and light enough to be suspended off the roof of the tunnel or the boom of a crane without compromising performance.

Much interest for this service has been sparked in North America due to the inherent speed and safety related to this method. Recently Jetcrete has been bidding on numerous jobs in South America as well. This spraying unit is of special interest there where manual application of shotcrete is still prevalent, at a high labour cost, not to mention safety risk. Of course Jetcrete provides conventional shotcrete / concrete services as well, as detailed below.





Remote shaft sprayer



Uranium mines – spraying



### ■ Cameco's Uranium Mines

Located in Northern Saskatchewan, these mines have relied on Jetcrete's services for many years now. Jetcrete has operated both surface and underground batch plants. These deliver concrete / shotcrete to transmixers, which then transport the product to the work area. These machines are capable of pouring concrete for the construction of pads and foundations. Also, these machines can deliver shotcrete to our shotcrete sprayers. Jetcrete, whenever possible, avoids hand spraying and relies on robotic spraying for almost all of its jobs.

### ■ Leeville concrete shaft lining in Nevada

For this job Jetcrete set up a state of the art batch plant. This plant, in conjunction with a fleet of new and modern mixer trucks delivered both shotcrete and concrete materials to the Turf Ventilation Shaft # 3. 41 MPa shotcrete was produced for the ground support of the shaft, which was sprayed by means of a custom built shaft sprayer. 70 MPa concrete was produced for the shaft liner. Both of these products needed to pass stringent temperature and quality requirements. In total, 21,650 m<sup>3</sup> of shotcrete and concrete were batched with great success.

Jetcrete would also regularly produce 30 MPa concrete for pad and foundations on surface. Mix designs were controlled by means of a computerized Marcotte system, which enabled Jetcrete to build a database of every minute detail of the process, information which is invaluable for future jobs.

### ■ Future Work

Jetcrete North America has been busy bidding on new projects. In spite of the slow market, Jetcrete has acquired new jobs and is bidding on very attractive projects which promise to keep Jetcrete in good standing for years to come.

Jetcrete North America is always keen on embarking on new and different types of jobs. An outside of the box thinking in conjunction with support from the engineering and operations teams at Thyssen Mining are key factors which ensure that Jetcrete remains at the forefront of the industry. If we can provide a safe and efficient solution to the ever evolving mining and civil industries we can ensure a bright and exciting future.

*Richard Miranda*



Underground mine dewatering system

## Murray Engineering Installs State of the Art Pump Station at Indonesian Mine

In August 2014 Murray Engineering was commissioned to install a primary dewatering system at a gold mine in Indonesia. The brief was to shift used water at 120 l/s at a vertical height of 130 metres using as many on-site parts as possible.

Murray Engineering designed the pumping and electrical systems and two trains of two 8/6 Warman pumps were selected as the final package. An electrical switch-room was built for the PLC-controlled 4 x 150 kW pumps.



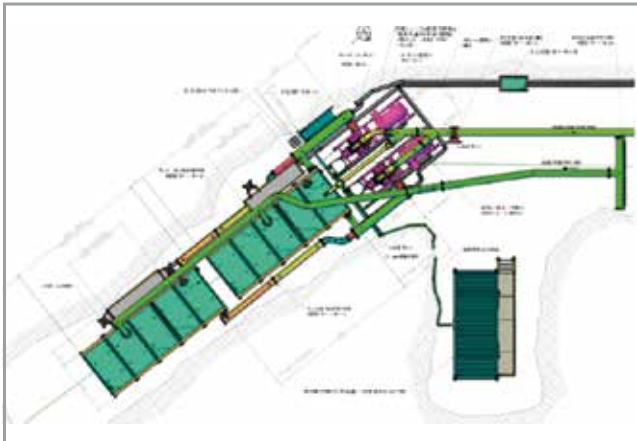

Underground design of the total mine dewatering plan

This dewatering system was successfully commissioned and operated for more than a year. Minor changes at the end of commissioning produced a final discharge rate of just over 200 l/s.

In 2015 increased working depths saw a rise in water volumes, exacerbated by inflow of surface water at almost 85 degrees Celsius. As the inflow and resulting high rock temperatures were affecting the mine’s viability it was decided that the local water-table should be lowered.

The first dewatering system was followed by a similar design for Primary Pump Station #2, which included a Clean Water Pumping System (CWPS) for the overall Total Mine Dewatering Plan.

Murray Engineering completed the electrical design, with the Pump Station #2 centrifugal pumps delivering the 85 degrees Celsius water directly to surface at 400 l/s.

The two pumps can operate in duty/stand-by or in parallel (duty/duty), depending on the requirement. Single or parallel pumping is automated using level instrumentation and a control system with touch-screen interface allows the operators to make user adjustable changes.

Water is pumped directly to surface via a Rising Main pipeline to minimise latent heat loading to the mine atmosphere.

The Life of Mine clean water pumping solution permits a seamless addition/extension at some point in the future.

The nominated pump chamber is 130 metres vertical distance from surface and uses an existing stockpile that was developed to create an area for tanks and switchgear.

The system enables clean water to be fed from borehole pumps and its location means minimal handling of hot water from the boreholes. The water stays free of solids media and no secondary systems are required.

Most of the underground dewatering will involve deep boreholes, so the reliability and performance of this system is critical to the mine’s development.

Murray Engineering fabricated the pipework, control room and 600kW soft starters at its Pinjarra facility. The pumps and motors were skid mounted and pre-wired to minimise installation times. Extensive pre-commissioning ensured on-site installation was as simple and expedient as possible.

All materials were containerised and of modular design. Murray Engineering sent out its own commissioning team which helped ensure water discharge rates in-line with design criteria.

Electrical steering





Schematic detailed views of the drainage system

Another challenge was to integrate the primary clean water pump station with the bore pumps. Murray Engineering installed a wireless communication set-up for the site dewatering systems. Data from remote I/Os, flow meters and piezos are transmitted to the main communication server on surface. The system can now be monitored/controlled and custom electrical interlocks can be developed with ease. This wireless system also collates data for various screens and graphs that are used to develop pumping efficiencies.

Murray Engineering delivered the right solution on time, on budget and in an extremely harsh environment. The high water temperatures were a major challenge. The modular design helped cut installation times and design costs were minimised thanks to the 'in-house' design and construct.

*Craig Shales*

Two line sections with two 8/6 Warman pumps connected in series at the place of installation







Major turning machine HEYLIGENSTAEDT DA 1000



New boring and milling machine HCW 1000

## TS Technologie + Service GmbH: New milling equipment for the in-house machine pool

**New production lathe and milling centre now complete the product portfolio.**

**In 2015 TS Technologie + Service GmbH took the decision for an expansion and modernization of its pool of machining equipment.**

### ■ Skoda-HCW 1000 milling and boring machine

The outdated, 40-year-old Union boring mill was replaced with the latest Skoda-HCW 1000 milling and boring machine. The new machine is designed for producing complex workpieces and all kinds of components to customer specifications. It features a cross-bed design with the turntable travelling in a longitudinal direction and a traversing column complete with headstock. The machine frame is constructed from rigid, vibration resistant grey-iron castings. The headstock and 130 mm-diameter extendable spindle travel vertically along the column. The machine is supported by the latest HEIDENHAIN control system and has an angle head with 1° indexing.

Complex and large workpieces are turned and milled with high precision

The machine tool is suitable for processing components for the power generation and steel technology industries and for specialised mechanical engineering work.

#### Specifications

Power output	37 kW at 4,000 rpm
X axis	4,000 mm
Y axis	3,000 mm
Z axis	1,500 mm
W axis	900 mm
Turntable/maximum loading:	2,000 mm * 2,000 mm / 12 t





Pic. top right:  
Traverse path of the machine



Pic. below right:  
Component for the wind power industry

### ■ HEYLIGENSTAEDT DA 1000 heavy-duty lathe

TS Technologie + Service has also procured another impressive piece of machinery for its turning shop in the form of a field-tested HEYLIGENSTAEDT DA 1000 heavy-duty lathe. The machine was purchased in Belgium and then went through a general overhaul at the Mülheim workshops in Germany. The control system was also upgraded in line with current technology by fitting a Siemens 840D system with ShopTurn controller. With the HEYLIGENSTAEDT DA 1000 the workshop has acquired a high-quality and extremely reliable turning and milling machine and is now mainly engaged in producing components for a well-known manufacturer of wind turbines.



#### Specifications

Faceplate	Ø 2000 mm
Power output	140 kW at 140 rpm
Z axis	10,000 mm
X axis	1,300 mm
Maximum workpiece diameter	2,600 mm
Maximum weight of workpiece between centres	50 t, or 70 t when supported (lunette)

#### ■ Conclusions

The workshop now has additional capacity for turning and milling complex components and large individual items and this increase in manufacturing potential has already attracted quite a few new customers.

TS Technologie + Service GmbH is therefore well prepared to meet the new challenges that lie ahead in the large-component manufacturing market.

*Nebojsa Babic  
Markus Walter*





## TS Technologie + Service GmbH: Positive developments in crane and gate technology

**New branch opens in Coblenz as T+S teams up with market leader.**

**This issue of the THYSSEN MINING Report has two important developments to report from TS Technologie + Service GmbH (T+S).**

The new crane and gate division has developed so well in just five years that another branch was opened up for business in Coblenz in February 2016. The products on offer range from small 50-kilogram crane systems to large 100-tonne crane

installations and from small-size garage doors to large steel gates with 30 m of drive-through.

The range of services includes the construction, repair, testing and maintenance of crane and gate systems, the inspection of high-bay warehouse systems and loading ramps for HGVs, fall-arrest systems for high-level workplaces and a complete range of slings and lifting tackle. Statutory testing can also be undertaken in all these areas in accordance with accident prevention regulations.

### ■ New division has expanded in just five years

As well as the opening of the new Coblenz branch the division has achieved another highlight by teaming up with the sales company Hörmann KG. T+S has now been working in partnership with Hörmann in the private client sector since the middle of last year. Intensive talks the year before convinced both parties that future collaboration could only bring real benefits to all concerned. Hörmann is Europe's largest manufacturer of house doors and gates and the market leader is considered as the 'Mercedes of the garage-door business'. As of now T+S is therefore able to supply private customers in Mülheim and Oberhausen with Hörmann top-quality garage doors and house doors in all standard sizes and colours, as well as bespoke items – and will soon





have exclusive rights to this market segment. As a perfect complement to this, all gates and doors can also be individually designed to the client's specific requirements.

#### ■ Cooperation with market leader Hörmann

The first joint marketing exercises with Hörmann have already paid off. In February the two partners had their own trade stand at the Mülheim Building Exhibition, an initiative that soon resulted in a multitude of on-site measuring appointments with potential customers. And an industry contract has also been wrapped up. In addition, the crane and gate division will again be taking part in Hörmann's 'Europe promotion campaign'. This involved specifically promoting selected house doors and garage doors to potential new customers at particularly attractive prices.

#### ■ Showroom planned for the best spot

As part of the cooperative venture with Hörmann there are also plans for further actions, including a permanent display of products on Aktienstrasse. Having a display in such an eye-catching position would provide T+S with an opportunity to showcase the products in their original form. In addition to these exhibitions the year will also see ongoing great attention paid to staff training and upskilling.



#### ■ The positive trend continues

The crane and gate division has made real progress in recent years and there is no reason to believe that this trend will not continue in future / the months ahead.

*Christoph Obermann  
Markus Walter*





Transport into the shaft hall



Erecting the first single-rope winder on the axle

## A new single-rope winder for Unterbreizbach number 1 shaft at the K+S KALI-owned potash plant

**In July 2015 OLKO-Maschinentechnik GmbH was commissioned by K+S KALI to supply and install a new single-rope winder and to remove the existing headgear sheave that was originally fitted in 1963. The new winding system was to be installed in the south compartment of Unterbreizbach mine number 1 shaft, which is part of the Werra potash plant in Thuringia. As well as the new headgear sheave the contract also required the delivery of a new braking system complete with electrical controls and all monitoring devices. The original main bearing, winder shaft and drive motor were all to be retained. A centralised unit was to be used to supply oil to the bearing, thereby replacing the three individual systems currently in use. The need to re-use some of the existing components was hampered by the fact that there were practically no design drawings available for the original items. Moreover, it was not possible to measure the fit of the sheave prior to its removal.**

The new headgear sheave is part of the double-compartment skip winding system that is used for transporting men and materials over a maximum winding distance of 763 metres. The winding speed is 12 m/s for materials and 8 m/s for man-winding. The sheave and its integral brake disc are 6.5 metres in diameter and the maximum load per compartment is just

below 35 tonnes. The modern DC motor was to be retained and so was not part of the conversion remit. The team had a time slot of about two weeks, during the summer holiday break of 2016, in which to remove the existing sheave, install the new one and commission the new braking system. The sheave had to be designed and manufactured in about ten months - an extremely challenging assignment for the technical departments involved. The actual fabrication work was undertaken by professional engineering companies from North Rhine-Westphalia under the continuous supervision of quality assurance personnel and project managers from OLKO. The firms involved were able to meet their tight production deadlines and the two sheave halves were delivered to the mine in time for the installation work to commence.

At the mine the fitting engineers from OLKO had already started to dismantle and remove the existing sheave, an operation that was completed within two days. The confined space called for some real precision work. The first sheave half, weighing some 16 tonnes, had to be manoeuvred into place over the drive shaft by means of an indoor crane and chain hoist. When the first half-sheave had been installed on the new clamping rings mounted on the old drive shaft the whole unit was slowly lowered into place. When this operation had been completed successfully the difficult manoeuvre had



Turning around the first half of the single-rope winder

to be repeated with the second half-sheave being lifted from the transport vehicle and lowered into the engine house. Once the second half-sheave had been mounted on the shaft the most difficult part of the operation was over.

Before the actual installation work began, and at various times thereafter, the assembly team once again used the operational stoppages to replace the winder's friction bearings and to install the hydraulic pipes for the braking system and bearing oil supply circuit. These preliminary activities helped win time for other operations to be performed.

At the same time as the head-sheave was being fitted the hydraulic pump unit for the new winder brake was installed in a cellar beneath the winding machine. For the Unterbreizbach project OLKO again opted to install its own COBRA01 (Controlled Olko Brake) braking system, which was fitted with Siemens control technology. Die COBRA unit is a multi-channel, delay-regulated and hydraulically-operated travel and safety brake whose 3+1 control circuits ensure a very high level of availability. A pair of brake posts, which were produced in OLKO's own workshops, enclose the head sheave and carry a total of five brake calipers. The main advantages of the OLKO braking system include high operational safety, even on installations that are prone to rope slip, full dependability in the event of a breakdown or an electrical or hydraulic malfunction in one of the control circuits, and the compact, space-saving design of the hydraulic unit.

After assembly and laying up the rope



Erecting the second half of the single-rope winder

After the braking control system had been commissioned, and just 17 days after the start of the installation work, the head sheave was run for the first time under no load. On the successful completion of this trial run the winding rope, which had been removed before the installation work commenced, was re-fitted so that a programme of tests could be carried out in both load and no-load mode. After a successful final inspection the installation was handed over to the satisfied client and was put back into service.

*Carsten Schmidt*





# The new lift and clamping system by OLKO-Maschinentechnik GmbH

**Koepe winding systems can be extensive to operate in terms of the labour required for the initial rope installation, in-service maintenance and subsequent rope changeover. Special appliances such as friction winches and HuK systems (lift and clamping device) have now become indispensable tools for work of this kind. OLKO has been producing friction winches and a new type of HuK for a number of years, but as the latter was individually designed for a specific project it had become technically outdated.**

In order to round-off the company's range of products a decision was taken in early 2015 to design and build a new HuK that would be in keeping with / according to best engineering practice.

In simple terms the HuK is a device with two gripper systems (a moveable clamping beam and a fixed clamping beam) per rope. The callipers fitted to the clamping beams use the wedging effect and the associated self-locking action to clamp the ropes firmly in place. This means that even ropes under load can be moved or hauled through/by the system. The mentioned self-locking action produced by the clamping beams means that the clamping effect is maintained even in the event of a power failure. Ideally the HuK should be located in the headframe above the buffer beams/girders.

Clamping system (calliper) fitted to clamping beam

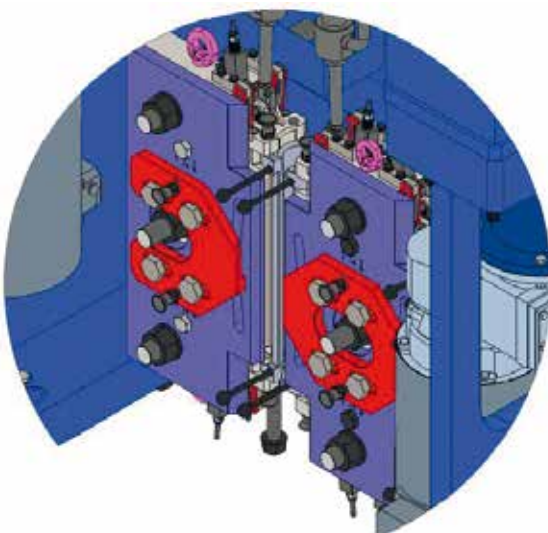

The technical design work on the HuK mechanical and hydraulic systems is now nearing completion and a patent has already been granted in Europe and in other international countries under patent number EP2585396. Development work has yet to be concluded on the necessary HuK control program, though a design study has already been produced laying down the specifications required for the control system.

A test rig has been specially constructed to investigate/probe the clamping functions of the HuK and to check the main components for wear. The test findings in respect of the function and operational safety of the HuK will be used for its optimisation.

The OLKO-developed HuK has a number of unique features that sets it apart from its competitors / differing from/ compared to known/common competitor products:

- The use of ball screws with gear motors for vertical lifting does away with the need for a complex hydraulic main drive.
- The overall height of the lifting device is reduced by opting for patented, reciprocally acting, wedge-shaped clamping elements (callipers).
- The HuK comprise two modules (one power panel and one lifting system) and has only one plug-in connector.

Calliper rope socket in open position

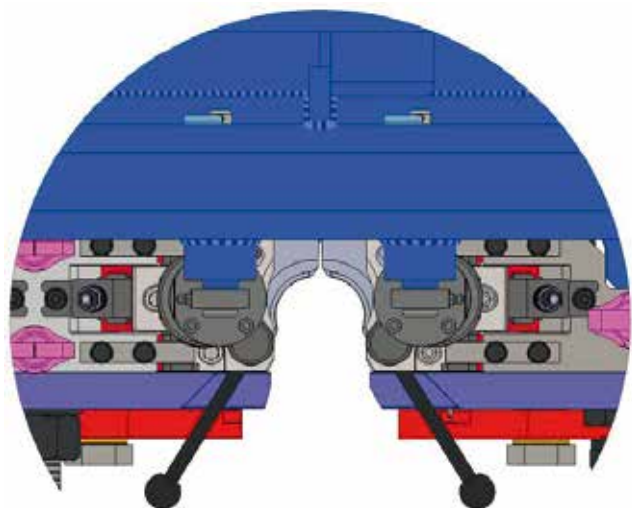

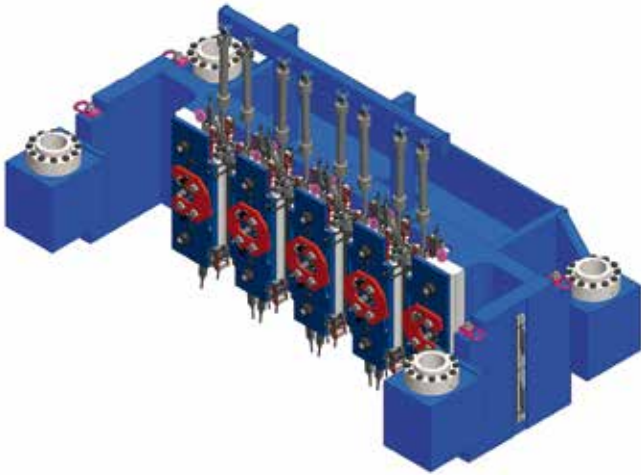

Moveable clamping beam on the HuK lifting device



HuK test rig under construction / during assembly

This makes assembly and dismantling a relatively simple process and means that the HuK does not have to be set-up as a fixed installation in the headframe.

- The HuK operator has support in the form of measurement data for the functions ,clamp' and ,release' for each rope and calliper, along with a display of the clamping status.
- Hydraulic clamping and release can be sensitively controlled in terms of speed and force limitation in accordance with the particular operation being carried out.
- The design takes account of the technical requirements that are anticipated as a result of the revision of the Technical specifications for shaft and inclined haulage systems (TAS) of 2005.
- Access to a specially built HuK test rig designed for extensive development work.

HuK lifting device

Following a series of presentations of the new HuK to several well-known clients commissions have now been received for rope changeover studies in South Africa and Germany.

*Achim Eiteneuer*

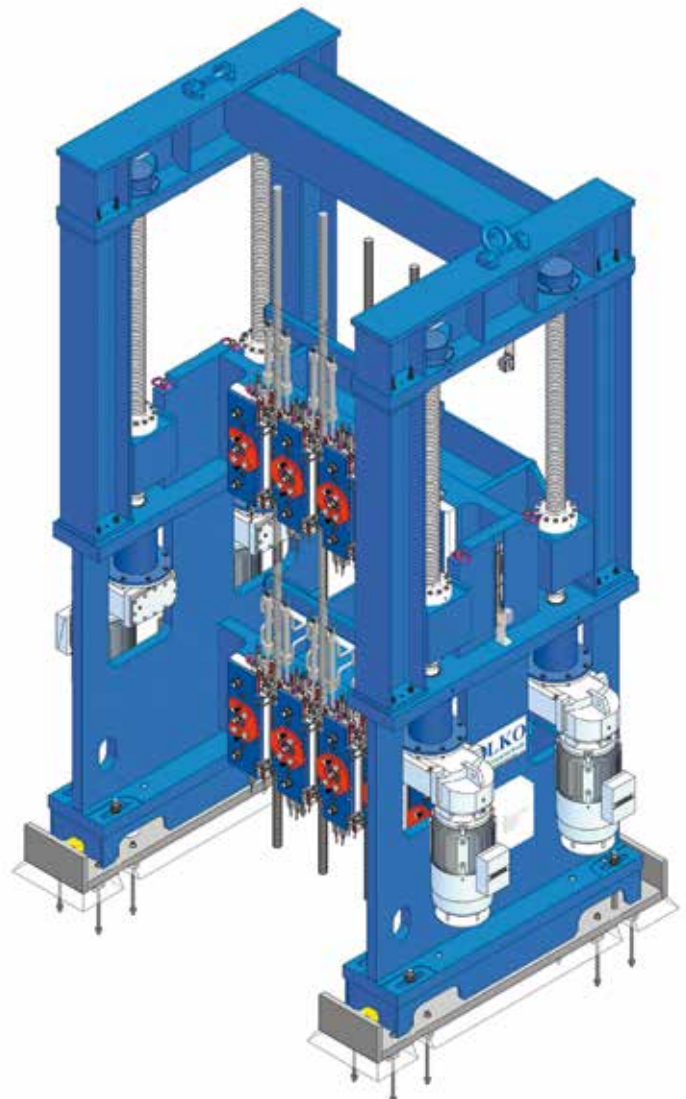

Test-rig data for developing the HuK control programs

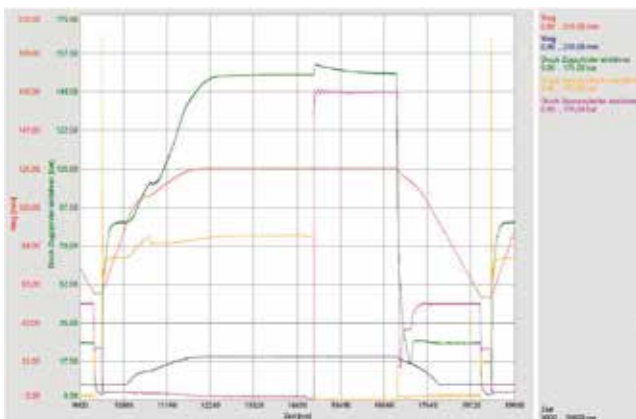





## Replacement of hot-gas generators in coal drying and grinding plant

A drying and grinding plant combines the two operations of coal grinding and drying in one. The plant essentially consists of a hot-gas generator, a coal mill and a filter, with the individual phases of the operation being combined into a single process. In this particular case the hot-gas generators, which date back to the years 1987, 1992, 1994 and 2000, are thermo-processing installations that are fuelled with natural gas. The original control equipment for these hot-gas generators used an outdated protection technology operating with a mechanical, integrated control system, with the combustion parameters being set using a cam plate and rod (to alter the fuel-air ratio). This type of control system is rarely used today, with electronic integrated controllers having almost completely supplanted the old mechanical technology. The gas-to-air ratio is calculated in a PLC (programmable logic controller) using quantity measurement data and the relevant variables are then passed back to the

gas-air regulator. Systems of this kind have to meet the requirements for thermo-processing plant as laid down in EN 746-2. The PLC is a safety-oriented control system.

As well as the age of the hot-gas generators various other factors were taken into account in the decision to replace the old units:

- Energy use would be optimised as part of the energy management system under DIN ISO 50001:2011, a standard to which EA has been certified since 2013.
- Savings would be made under the CO<sub>2</sub> trading scheme, in which EA has participated since the reporting period 2013 to 2020 of the third trading regime.
- Improved regulating and control parameters (electronic integrated control system) would help reduce energy usage and cut costs.
- The plant could be converted to burn another fuel: blast-furnace mixed gas.

Schematic presentation of the six drying and grinding plants

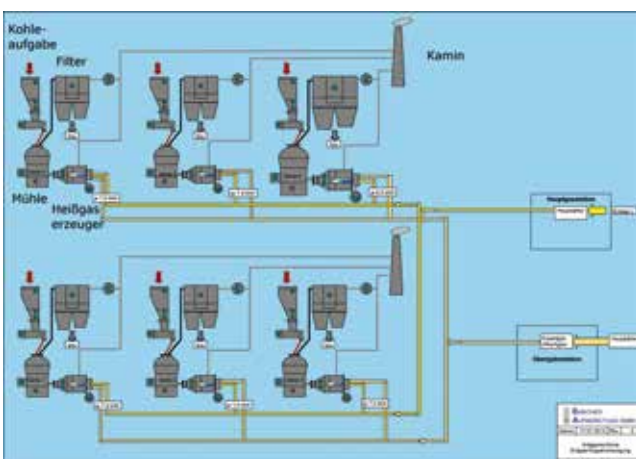

In 2014 a decision was taken in consultation with the client thyssenkrupp Steel Europe AG (tkSE) that all six grinding plants would be replaced over a period of about three years and at the same time prepared for the use of blast-furnace mixed gas as fuel.

Blast-furnace mixed gas is a by-product of the iron and coking making industries. It is manufactured by mixing together coke gas and blast-furnace gas in order to obtain a calorific value that is as uniform as possible. The use of blast-furnace mixed gas at EA, in collaboration with tkSE, will result in a reduction in CO<sub>2</sub> emissions.



Control station with gas connection



Control station HGE

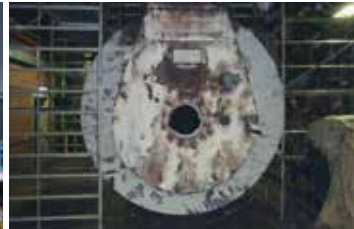

Disassembly nozzle



HGE inside view

The decision by EA to switch away from natural gas and instead to use the available blast-furnace mixed gas will save on CO<sub>2</sub> emissions at a level equivalent to that of a town with a population of over 20,000.

**Gas consumption figures 2012 to 2016**

year	gas consumption [mill. kWh/a]	pulverised fuel production [mill. t/a]	equivalent single-family home burning natural gas [per unit]
2012	152	1.50	approx. 5,100
2013	175	1.70	approx. 5,800
2014	171	1.77	approx. 5,700
2015	183	1.92	approx. 6,100
2016	195	2.01	approx. 6,500

\* Comparison: One single-family home of 200 m<sup>2</sup> with four persons consumes about 30,000 kWh/a of natural gas.

The upgrade will give the hot-gas generators the technical capability to burn blast-furnace mixed gas. In order to implement the new mixed-gas burning regime the final stage of the refit will require new supply pipes to be laid from the tkSE site and new internal pipework to be installed at the EA processing plant. To this effect efforts are under way to obtain a change-of-use authorisation from the relevant authorities in compliance with the Federal Emission Control Act.

Meanwhile four of the gas generators were converted. These units are currently being run on natural gas. The conversion operation, which requires around three weeks for the installation and cold start-up process, has to be planned down to the last detail and coordinated with tkSE. Supply problems that could affect deliveries of pulverised-fuel to customers are to be avoided at all costs. In order to achieve this the conversion work being carried out by the fuel-burner suppliers is supervised and organised by EA in such a way that the company's technical departments will always have completed the following actions before any installation work commences:

- engineering work for connections to be made to the control system, including the testing of all connections and cable paths
- preparations to facilitate any dismantling work needed
- checking and modification of circuit diagrams
- establishment of communication links between the burner controls, the equipment controls and the plant management system, and re-design of the plant process screens
- preparations for new service ducts and supply lines.

As the conversion work was under way on the hot-gas generators a major overhaul was also performed on the entire grinding plant in order to make the most efficient use of the enforced plant downtime. This called for some close synchronisation between the various maintenance groups in order to ensure that operational safety standards were maintained and that everything ran smoothly and in a well coordinated manner.

The technical departments responsible for the electrical and mechanical engineering had to provide close supervision and support for the personnel from the burner suppliers throughout the installation and commissioning period. It was important to ensure that all construction and assembly work was fully in keeping with the operating regime of the grinding and drying plant. Hot start-up could then be carried out once all installation work and cold commissioning had been completed and after the plant had been inspected and approved by the TÜV in accordance with EN 746-2. The hot commissioning phase also involves a re-testing of all operating parameters. The actual burner output is set by the supplier. EA checks that the new components are properly integrated and embedded into the grinding and drying system and carries out an initial performance review. A performance test is then conducted in order to check the warranty values and conditions. After a one-week trial period the plant is then handed over to EA for normal operation.

*Martin Pfeil*





OLKO Ponton dredger on the Conexpo in Las Vegas

## Pontoon dredger goes Las Vegas

**It was September last year when we first contemplated the idea of exhibiting our newly developed pontoon dredger to a wider audience at the Conexpo international trade fair in Las Vegas. Ahead of this there were all manner of details to work out, the most important of which naturally was whether our 'headline act' would be ready in time to catch the last available ship that would be sailing to Los Angeles on 9th January 2017. With all lights on green it was clear to us straight away that this was the way to go!**

Work then started on organising the exhibition project. The negotiations that followed involved show organisers, stand fitters, crane-hire firms, customs authorities and a catering company. The design of the exhibition stand and the promotional literature was a collaborative effort whose aim was to showcase the Thyssen Mining Group along with our affiliate Thyssen Mining Construction of Canada Ltd. and our subsidiary OLKO-Maschinentechnik GmbH. The stand opened to the public exactly on time on 7th March 2017.

Conexpo, as it is called in Las Vegas, opened its doors on the same day and ran until 11th March. This is a very well attended show that displays construction machinery for the north and south American markets. And this is precisely where we wanted to exhibit our new floating dredger.

Las Vegas is a crazy place and so we wanted to create an equally crazy design for our dredger. We finally decided to give the pontoons a graffiti-style appearance complete with the image of an alligator, a creature that is equally at home in the swamps and waterways as our dredger will be. This meant finding a prime location for the stand so that it would attract the attention of as many showgoers as possible and generate real interest from potential customers. We were completely successful in this aim. Our display area was located right at the entrance and exit points for the exhibition centre. Our 40-tonne machine with its Atlas upper carriage was now ready for the show, along with some 2,800 other exhibitors on the 220,000 m<sup>2</sup> exhibition area. Every one of the 150,000 visitors to the show had to walk past our dredger and almost all of them had to be photographed with it or took photos of it.

In no time at all we were receiving visits from film and television crews who wanted to do interviews with us and film the dredger for various magazines. During its time at the show the dredger was nicknamed 'the blue beast' and everyone who attended knew of it. Very soon those of us who manned the stand were also being greeted with the same nickname!

In the course of all these discussions our main objective was to press home the advantages of our dredger in comparison

with all the traditional machines being marketed by other companies.

This involved focusing on a number of key design features that were aimed at making the machine more user friendly and keeping wear and tear to a minimum:

- the drive components for the pontoon dredger were designed, produced and selected for high availability and reliability under extreme conditions in swamps and wet dredging zones
- the chain drive system features a single chain assembly for each pontoon
- the chain itself has a built-in breaking point for overload situations so that a controlled failure can be achieved without any loss of chain function.

After five exhausting days at the show there is no doubt whatsoever that our visit to Conexpo had paid off. We were able to present ourselves, our product and the companies we represent to visitors from all over the world and in doing so we really managed to attract interest from a lot of prospective buyers. Our dialogue partners expressed very positive views about our product. In all we were able to log more than 50 show reports on potential customers who wanted further information and a quotation tailored to their specific requirements. These prospective buyers came from every corner of the globe: Australia, South Africa, Argentina, Texas and even the Philippines.

However the high point of our visit to Conexpo was to come right at the end: we were successful in selling the exhibited dredger to an American building contractor who then took



great pride in having his photograph taken on the stand for his company brochure.

We now intend to expand this product area and will work to position our ‚blue beast‘ on the world market as quickly as possible.

For everyone involved, including our colleagues from Canada, the show was a unique experience with a very pleasing conclusion, which we now hope to build on.

In this particular case the featured image was that of an alligator, but customers can of course choose any design according to their own personal preferences.

We hope that this report has also aroused your interest in our pontoon dredger. If you have any further questions please do not hesitate to contact us at any time.

*Markus Beermann*





# Insights into shaft construction practice in the early 20th century

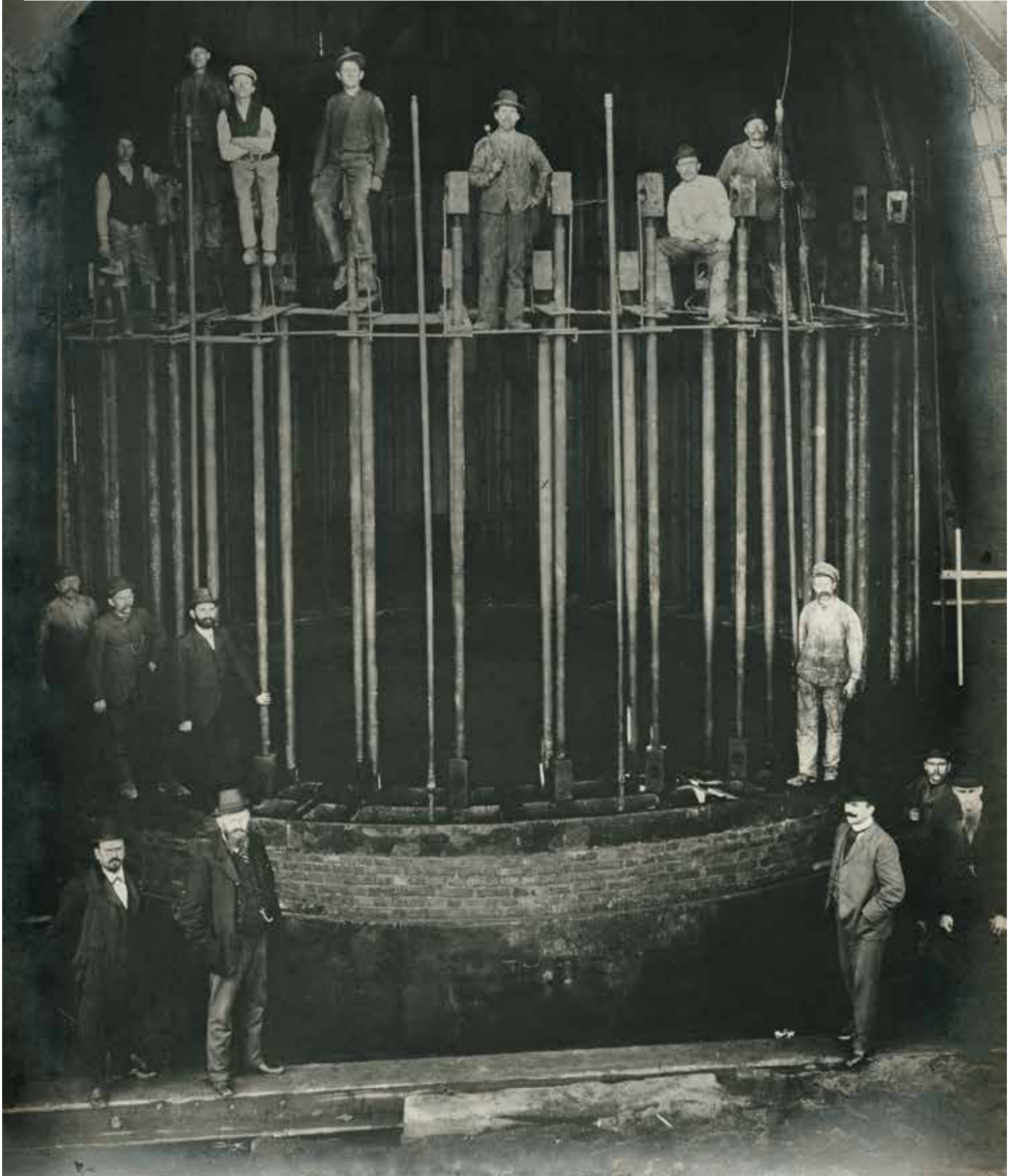

Gewerkschaft Deutscher Kaiser, shaft construction section: number 5 shaft, anchor bolts on the pressure system at the caisson head, circa 1901

**Shaft construction has developed enormously since the very first mine shafts were sunk more than 7,500 years ago. The Industrial Revolution that began in the mid-19th century provided a huge stimulus for shaft building in that it not only produced much improved engineering solutions for sinking deeper shafts but also demanded increasing amounts of resources such as coal and iron ore in order to satisfy the growing needs of industry. This surge in demand resulted in an ever growing number of shaft sinking projects. This paper will seek to trace a little of the history of the most important German shaft construction methods as they were around 1919, the year when THYSSEN SCHACHTBAU GMBH was first established.**

### ■ Conventional sinking

Conventional sinking was and remains the original and most commonly used method for constructing a mine shaft in stable, low water-bearing ground. The rock is excavated using a combination of hand-held and mechanised equipment, or by successive drilling and firing operations, and the debris is transported to the surface in a kibble.

At the beginning of the 20th century hand-held tools such as picks, shovels, crowbars and club hammers were often employed to remove the loose overlying material in the foreshaft zone. A low powered steam-driven winch was used to remove the debris and bring in the support materials. When the excavation encountered solid rock the operation would switch over to drilling and blasting. Dynamite cartridges or compacted gunpowder were used to provide the explosive force and the charges were detonated by fuse or by shotfiring cable. Electrical detonation cables clearly had major advantages over the unreliable fuses and were therefore the preferred method, if available.

As the strata was rarely completely water-free and flooding had to be prevented at all costs the sinking operation had to be provided with an effective water evacuation system. By the year 1900 inflow rates of about 50 litres a minute could be dealt with simply by scooping the water into the dirt-filled kipples. If increased levels of water were encountered this had to be removed by employing additional kipples, these being solely assigned to dewatering work, by pumping or by using a Tomson water drawing system. The Tomson method comprised a dedicated dewatering system with kipples that were specially built to operate close to the shaft sides. These kipples had a holding capacity of about 12 m<sup>3</sup> and were designed to protrude as little as possible into the shaft compartment. The water was extracted from the deepest

point of the sinking floor using pumps that were suspended in the shaft. The pumps delivered the water to a number of collector tanks mounted on the side-walls above the floor and the contents were subsequently taken to the surface using the kibble system. The kipples were immersed into the collector tanks from above so that the water could enter through valves in the kibble floor. When the kipples were withdrawn the valves would close and the filled container could then be raised to the surface. Operating at a shaft depth of 600 m this system was capable of extracting around 240 m<sup>3</sup> of mine water an hour in each kibble.

### ■ Boring technique for a flooded shaft

If the shaft was being sunk through stable but heavily water-bearing strata conventional excavation methods could not be employed as the inflowing water could not be removed at a sufficient rate. In order to excavate a shaft even under these adverse conditions shaft boring techniques were developed that could be used in 'dead water', as these flooded conditions were called. Originally devised by the German mining engineer Karl Gotthelf Kind in 1849 as a percussive boring method, this system was subsequently improved by the Belgian engineer Joseph Chaudron. The boring process was then known as the Kind-Chaudron method. The boring head consisted of a large percussive boring bit that was driven into the rock by means of a free-fall device suspended above the drill head. After each blow the bit would be rotated slightly so that the full cross section could be excavated step by step. A smaller percussive bit was first used to make a pilot hole so that the main bore could then be excavated as vertically as possible and the drilling mud removed. The diameter of this pilot hole was usually between one third and one half that of the full shaft section. As the pilot hole always constituted the deepest point in the shaft sinking the drilling debris could be removed between each cycle by means of a sludge bailer. One of the drawbacks of the system was that the entire drill string had to be withdrawn each time the boring head had to be changed over and each time the sludge was being bailed out. The Kind-Chaudron system was employed for shafts up to 400 m in depth and remained in operation until 1915.

A much improved version was developed in 1896 by the Westphalian mine manager Fritz Honigmann. This Honigmann boring installation comprised a continuously rotating boring head, a hollow drill rod and an inverse mud flushing system for removing the cuttings. The drill cuttings were drawn up through the drill rod by a process similar to that of an airlift pump with compressed air being forced up through the mud-flushed drill rod from below. The introduction of compressed



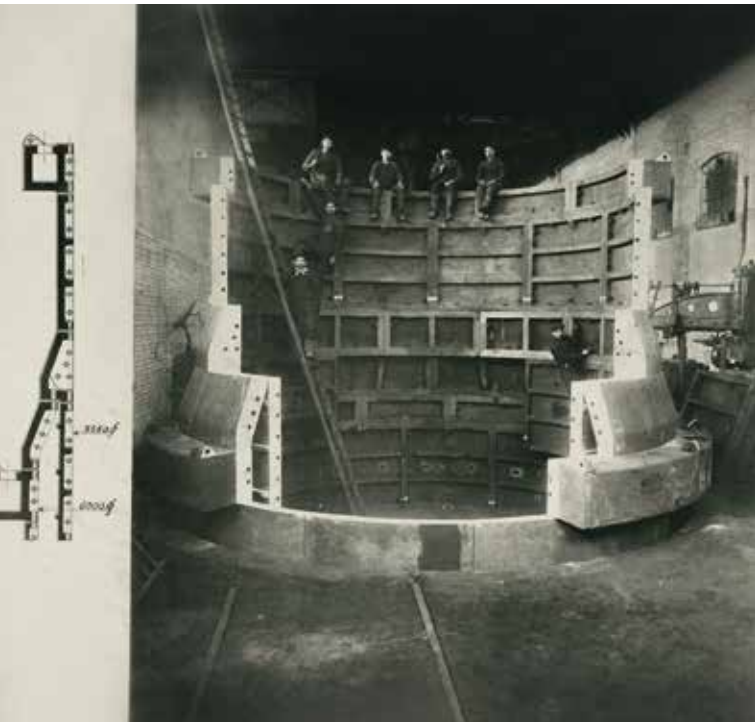

Gewerkschaft Deutscher Kaiser, shaft construction section: tubbing elements for a conventional shaft sinking, Société Liégeois Seraing, circa 1905

air ensured that the specific density inside the pipe was lower than that of the flushing mud in the shaft, with the result that the contents of the pipe were forced upwards and a continuous volume flow was generated. The Honigmann system was employed down to depths of 500 m and this technique laid the foundations for the drilling technology we know today.

### ■ The freeze method

If the strata were unstable or excessively water bearing any shaft sinking operation could only be carried out with the greatest of efforts, or indeed not at all. The freeze method solved this problem, as freezing the water in the strata not only created a stable body of ground but also effectively ruled out the risk of flooding as the surrounding ice wall effectively sealed off the entire shaft column. This shaft sinking method involved drilling a series of concentric holes around the shaft centre line and down as far as the stable, non water-bearing horizons. Each hole was lined with a closed casing shoe and downpipes were then inserted into the freeze pipes so that coolant could subsequently be circulated through the holes from the surface. The natural heat of the strata was thereby continuously drawn away, the cooling medium being constantly re-cooled as it passed through the compression refrigeration machines set up on the surface. There had to be a sufficient temperature difference between the coolant and the strata so that the

heat could be drawn off efficiently. This technique has over the years been capable of generating temperatures of as low as minus 40 °C. Extracting the heat from the ground in this way caused the strata to freeze around the proposed shaft column, thereby creating a cylindrical ice wall.

This technique was invented by the German engineer Friedrich Hermann Poetsch in 1883. However, a ground freezing method had previously been used to sink a mine shaft in Wales in 1862. In the latter case the strata around the shaft line was frozen section by section from the sinking floor and unlike the Poetsch system the Welsh operation proposed freezing the ground over the entire depth of the unstable and/or water-bearing zone.

### ■ Caisson sinking method for flooded shafts

Unlike conventional sinking, in which the shaft lining was installed after the shaft profile has been excavated, the caisson method provided for the permanent support system to be installed as the sinking advanced. Moreover, the mine water did not have to be continuously pumped away, as this technique could be used in a flooded shaft. The caisson system was based on the principle of an enclosed, circular cylinder settling down under its own weight through relatively soft, unconsolidated ground. In order to facilitate the action of sinking into the strata the bottom edges of the cylindrical support were fitted with drive shoes in the form of wooden or steel blades. The constant force acting against the floor of the shaft caused the caisson to slide deeper into the ground. Additional support sections, consisting of watertight tubbing elements bolted together, were attached to the top of the support system at the mouth of the shaft. This meant that the entire shaft was always supported and could not cave in. However, the increasing shaft depth also created greater friction between the support system and the sidewall, so that in spite of its weight the caisson shaft would inevitably become stuck. Several technical solutions were developed in order to overcome this frictional resistance and enable the sinking to progress further. One such solution was to install hydraulic presses or winches at the shaft collar in order to add to the deadweight of the caisson and so drive it into the ground. However this placed huge stresses on the support system and when the shaft finally touched bottom it was frequently found that the tubbing elements had suffered deformation damage. In order to improve the anti-friction properties of the caisson in the strata, and hence to reduce the amount of force required, an anti-friction fluid was pumped in between the support system and the shaft walls. This reduced the friction and increased the sinking performance. The demands being imposed on the support system also created problems. At greater depths the support

system had to be made stronger, which meant an increase in size. Keeping the same excavation profile therefore resulted in a slight reduction in the finished diameter. Increasing the cross section would also result in greater friction, as this would at the same time increase the circumference and hence the lateral surface of the support system. In an attempt to make the shaft support stiffer and heavier engineers began to develop the 'compound shaft' system, in which the normal tubing elements were fitted with additional reinforcing rings while the gaps between were filled with brickwork or concrete. This made for a much sturdier and heavier support system. As the support system would still inevitably become stuck at a certain depth, in spite of all the efforts made, a solution was tried out in some cases whereby several caissons were inserted one inside the other. If the outer caisson would not penetrate any further the sinking would be continued with the next-smallest one. Of course the finished diameter of the shaft would also be reduced each time a new caisson segment was introduced. Notwithstanding these efforts the maximum sinking distance achieved per caisson segment was 150 m.

Equipment of various kinds was employed for the sinking operation, including bucket-chain dredgers and grab dredgers. The sinking debris could also be removed using the airlift pump technique, a system that was able to raise the material from the sinking floor to the surface without the need for any moving parts such as valves etc.

### ■ Floating-in the support system

If the shaft was being sunk in 'dead water' the support system had to be floated into place, as the delivery capacity of the available dewatering pumps was inadequate and the stability of the shaft was threatened.

In order to 'float-in' the shaft support the entire tubing support system would be assembled piece by piece on the surface and gradually lowered down into the flooded shaft. As the bottom section of this support column was made to be watertight, and all the other tubing rings were also bolted together with lead seals to create a fully watertight structure, the entire support system would float in the water. Because of this buoyancy effect there was no need for any lifting or retention devices to support the structure. If the buoyancy force of the structure became so great that it would not sink any further, water was poured into the support column to raise its weight and thereby increase the immersion depth. When the support system finally came to rest on the floor of the shaft more water would be poured in and the annulus between the support cylinder and the shaft walls would be filled with concrete. When the backfill concrete had set hard the support system would be pumped dry and the shaft could



Gewerkschaft Deutscher Kaiser, shaft construction section, Friedrichsfeld system (boring bit) circa 1912

then be fitted with its permanent fixtures. If the shaft was already lined with supports to a certain depth the next section would be floated-in from the shaft head as described. However, the height of the tubing section being installed was only that required for the lower part of the shaft. The new support system, weighted down as it would be with water, would then be fitted with a watertight cover. This support pipe, which was sealed at both ends, could then be lowered into the shaft, set down on the shaft floor and concreted into place. When the upper section of shaft had been drained of its water the plate covering the lower support section was removed and the bottom section was then also pumped dry.

*Simon Klösger*

#### Sources:

'Shaft sinking by hand. A collection of practical experiences'. A. Hoffmann, Freiberg Mining Academy, 1911

'Shaft sinking under difficult conditions', J. Riemer, Freiberg Mining Academy, 1905

'Mining machinery. A collection of handbooks for officials', H. Bansen, Verlag Julius Springer, 1916

'New mining methods', volume 10, issue no. 10, October 1980

All pictures: thyssenkrupp company archives, Duisburg





Atrium Hotel The Fontenay

## DIG DEUTSCHE INNENBAU GMBH – Your partner for high-end interiors

**DIG operates nationwide as a specialist contractor for all aspects of integrated interior finishing. Great emphasis is placed both on high-quality execution and also on the efficient management of all the different technical skills needed to complete the project.**

Modern project implementation not only means harmonising all the planning and execution stages of the finishing work but also calls for these operations to be integrated seamlessly into the other key services, such as shell construction, facade work and in-house technology. DIG is geared towards this challenge and has the capacity to resolve even the most demanding tasks quickly and to the highest possible standards.

The DIG range of services comprises consultancy, design, organisation and execution and covers everything from one-off projects to complete fit-out schemes. This includes solutions based around standard systems as well as the use of specialised individual components and complex single-unit production runs. The fit-out constitutes the fourth pillar of

the entire construction process, the other three being the shell structure, the facade and the in-house technology. All the different crafts needed to complete the building have to be coordinated with these first-phase operations – preferably at the planning stage and certainly during the construction phase. DIG has the technical and organisational know-how needed to integrate all the fitting-out tasks successfully into the planning and construction workflow. Possibilities here range from customised add-on and finishing packages right through to all manner of interior fixtures from A to Z.

Two of the most significant DIG projects of recent years have been:

- The Squire, Frankfurt (approx. 100 mill. euros)
- Lufthansa Headquarters, Frankfurt (41 mill. euros).

[For a full reference list see:  
<http://www.deutsche-innenbau.de>]

As well as the two major contracts cited above DIG is also involved in a number of other interior finishing projects, including the ‚Living Circle‘ (a new residential housing





Inside view

development) and various upgrades at the university of applied sciences (both in Dusseldorf), the offices of the Administrative Professional Association (VBG) in Hamburg, the NOVE office complex in Munich and a replacement building at the Ruhr University in Bochum. A further two Hamburg-based projects are also presented below.

### ■ Hotel The Fontenay, Hamburg

Back in 2015 DIG was awarded the contract to fit-out the 5-star THE FONTENAY hotel in Hamburg.

The developers Kühne Immobilien GmbH, with owner Klaus Michael Kühne, have chosen an Alster riverside location to build a hotel ‚without corners or edges‘ that has been conceived to meet the highest standards of European luxury.

The project has already attracted widespread public interest and the hotel, like the Hamburg Elbphilharmonie, has now become another key landmark in the city. The architecture is based on free-flowing curves and a whole array of special design solutions that are like no other anywhere in Germany. A special ‚ceiling panel‘ working group was set up with industry partners Knauf in order to draw up the detail designs needed to produce the individual segments for the free-form shapes and one-off components, which were then to be fitted together on site like pieces of jigsaw puzzle. Yet that was not the end of it! Because of the density of the technical equipment and service systems installed beneath the ceiling slabs the entire ceiling arrangement had to be supported on a specially constructed and statically calculated steel sub-structure. The entire assembly was completed by a heating-cooling ceiling system with an elaborate acoustic plaster finish.



View from the lake Alster

As well as meeting very high technical specifications the project focused on producing a surface finish of the highest quality, which involved the application of different wall coverings and various stopping and plastering techniques that would lend the building its unique character.

Following several substantial design changes on the part of the architects the aim now is to complete the project by the summer of 2017, as the hotel is to be used by one of the national delegations attending the forthcoming G20 Summit.

### ■ The Elbphilharmonie, Hamburg

At the beginning of 2016 we were awarded the contract to complete the interiors of 42 luxury apartments at the Elbphilharmonie Hamburg. This involved the installation of drywall partitions and ceilings, heating-cooling ceiling systems, internal wooden doors and recessed frameless all-glass doors from Italy.

What makes this project so special is the fact that incredibly high standards of styling and quality had to be met within the narrowest of spaces. These stringent requirements are reflected in the purchase price of each apartment. With units selling for between 20 and 50 thousand euros a square metre, the building is now one of Germany’s most expensive properties. The completion date is scheduled for March 2018.

*Marco Malm*





## The work of the Purchasing and Logistics Department

**„No place too far, no load too heavy‘, so goes the motto of the P + L department.**

**The Department incorporates two functions, namely procurement and logistics, whose tasks and responsibilities are necessarily linked closely together in order to ensure that data and messages are always communicated quickly and efficiently.**

All P + L operations are currently handled by a staff of thirteen, with eight working in the purchasing office and five in the logistics section.

The purchasing office is responsible for ensuring that all the materials, equipment and services required for operations at our project sites at home and abroad are procured under the most favourable financial terms. This is done in collaboration with the various technical departments using the double verification approach. This ensures that in addition to the commercial aspects, such as price, delivery time, payment conditions and warranty period, the technical parameters relating to specified quality standards and performance figures are also adhered to. The central purchasing department operated by THYSSEN SCHACHTBAU HOLDING also manages all the procurement activities of the subsidiaries TS Technologie und Service, Thyssen Schachtbau Immobilien and OLKO-Maschinenteknik.

In 2016 the Purchasing Department was responsible for procuring some 60 million euros worth of goods and services, mostly for our international projects.

„After the purchasing comes the transport‘, and this is where the logistics section goes into action. Our logistics staff are

responsible for ensuring that all the equipment and materials ordered are transported to their various destinations on time and in the most cost effective manner. Here it is worth noting the huge amount of preliminary work that has to be done when arranging for exports of this kind, especially to Russia. When shipping goods to this part of the world each individual item in the consignment (from a bolt to a complete machine) first has to be cleared with the customs authorities in Russia so as to avoid holdups at the border crossing. This process is handled by customs brokers in Russia who work together with personnel from the Logistics Department. More than 5,000 individual items were cleared for export in this way during the financial year 2016.

In the summer of 2014 this customs clearing procedure became even more labour-intensive as a result of the sanctions imposed on Russia by the European Union. Many of the parts scheduled for export now first require authorisation from the BAFA (Federal Office of Economics and Export Control) in line with the categories of products on the sanctions list. These goods cannot be exported without the agreement of the BAFA. We have so far always been successful in obtaining official approval for the various transactions and projects that have come our way.

In 2016 the Logistics Department shipped more than 4,100 tonnes of materials and equipment to and within Russia. „No place too far, no load too heavy‘ - the Department motto says it all.

*Andreas Masthoff*



## No specialist mining services without mining technologists – vocational training in the mining industry

**Why does THYSSEN SCHACHTBAU, a specialist mining contractor, still need people with mining qualifications? They say that ‚Germany doesn’t have a mining industry any more’. But if that were really true then even THYSSEN SCHACHTBAU would accept the fact and live with its consequences. Yet despite the economic difficulties facing the international commodities markets the situation for TS presents quite a different picture and in the international arena in particular the shaft sinking company fully intends to remain an effective market player for the foreseeable future.**

THYSSEN SCHACHTBAU realises that there is a distinct skills shortage on the job market that affects practically every sector with a mining technology background. As far as specialist mining services and drilling assignments are concerned it is becoming increasingly difficult to provide the required number of experienced mining technologists for the duration of the project. What is more, the mining profession is even finding it hard to attract career changers, that is to say newcomers from traditional handicraft trades who can be prepared for work in the mining industry by way of on-the-

job induction and training in accordance with regulatory authority requirements. While earnings in the mining industry are still above average, there is of course significant competition from what are perceived to be more comfortable jobs where people do not have to ‚get their hands dirty’. Speaking of which, the highly qualified personnel who work for TS at the company’s various drilling and shaft construction sites have an opportunity to use their hands to generate some real and unique value by applying the latest tools and technologies.

For this mining specialist the technical skills of the company workforce are an essential factor when it comes to delivering new projects and assignments. Retaining a well-balanced age structure within the workforce is also vital for protecting and maintaining the twin professions of mining and deep drilling technologist. Continuous skills training creates the solid employee base that is needed to ensure that future contracts are handled in a professional and competent manner. Even in the diminishing German mining industry it will still be possible to apply long-term added value to this service sector.



And there is another aspect to all this, namely the ongoing, traditional attachment that we have to the shaft construction business that is in stark contrast to today's general trend for personal, short-term and mostly fruitless profit-seeking. With us, employees are able to develop a relationship of trust built around a longstanding partnership with THYSSEN SCHACHTBAU. Sound technical and practical training provides the basis for company-specific core skills.

There is clearly added value in the working environment, which is linked to performing quality work at the highest level. The key to avoiding accidents and errors lies in adopting a professional attitude to the task at hand, with the wealth of experience held at the company being tied into a continuous learning process.

TS has decided that for 2017 the two training apprenticeships of 'underground engineering technologist' and 'deep drilling technologist' will be provided for the first time as part of the traditional career path.

The requirements for skilled employees include familiarity with and command of the highly mechanised and part-automated processes employed in the mining industry and a high degree of specialist knowledge in the field of mining engineering and other associated areas. Mastery of the latest and in some cases complex mining technology will be part of the daily routine. Some of the specialised fields of application and associated qualifications involved are presented in summary form in Tables 1 and 2 below.

What are you waiting for? Apply now for a training place as a underground engineering or deep drilling technologist with one of the world's leading mining companies.

*Markus Westermeyer  
Hubertus Kahl  
Marc Krause*

**Broad operating scope for mining and deep drilling technologists**

<b>Mining technologist/Underground engineering</b>	<b>Mining technologist/Deep drilling</b>
Construction, operation and preservation of mines and shafts	Deployment of drill rigs (above and below ground)
Mine roadway development	Mineral winning
Installation of ventilation structures and equipment	Exploration
Mine de-watering work	Application of geothermal energy
Construction and maintenance of haulage and conveying systems in shafts and roadways	Construction and operation of underground storage facilities

**Key qualifications for mining and deep drilling technologists**

<b>Mining technologist/Underground engineering</b>	<b>Mining technologist/Deep drilling</b>
Mining technology, mineral winning, landfill and stowing, support techniques	Mechanical engineering and drilling equipment
Mining logistics	Deep drilling techniques and technology
Technical principles of control technology, pneumatics and hydraulics	Fundamentals of geology with specific focus on areas of specialisation
Mine climate and ventilation technology	Electrical installations and drive systems
Exploration and geology	Basic principles of pneumatics and hydraulics
Occupational health and safety	Occupational health and safety
Mechanical engineering and assembly	Mining legislation and the application of environmental regulations
Basic metalworking	
Electrical installations and drive systems	
Drilling technology	

**COMPETENCE BY  
EXPERIENCE.  
YOUR PARTNER.**



**THYSSEN  
SCHACHTBAU**

[www.thyssen-schachtbau.com](http://www.thyssen-schachtbau.com)



